

Ästhetik im Bad
Bathroom aesthetics



Ästhetik im Bad
Bathroom aesthetics





Oliver Jörger – Geschäftsführer und Designer
Managing Director and Designer Oliver Jörger

Tradition und Innovationsfreude seit 1909

TRADITION AND THE JOY OF INNOVATION SINCE 1909

Vier Generationen prägen bis heute das deutsche Familienunternehmen Jörger, das mit seinem Namen international für erlesene Ästhetik im Bad steht. Seine weitreichende Geschichte repräsentiert das Wappen der Familie.

Das Fundament für die bestehende Tradition legte Bernhard Jörger: Am Hof von Großherzog Friedrich II. von Baden startete er als Blechnermeister die Bäder der adligen Familien aus und richtete im Mannheimer Schloss die Installationen ein. Mit dieser hohen Reputation gründete er im Jahr 1909 gemeinsam mit seinem Vater Albert das Unternehmen.

Gerhard E. Jörger setzte ab 1965 mit seinem Fachwissen als Ingenieur und seinem Gespür für Stil und Design neue Maßstäbe: Zukunftsweisend verband er höchste handwerkliche und technische Qualität mit besonderen, ästhetischen Ansprüchen. In dieser Tradition steht der Geschäftsführer Oliver Jörger und prägt bis heute als Designer den modernen Stil von Jörger.

There are four generations that to this day have characterized the family-owned company Jörger which has dedicated its name, internationally, to sophisticated, aesthetic bathrooms. Its far-reaching history is represented in the family coat of arms.

The foundation for the current tradition was laid by Bernhard Jörger: At the court of Friedrich II of Baden he was entrusted with the task of furnishing the exclusive bathrooms and was responsible for the installations in the palace of Mannheim. In 1909, with this high reputation, he founded the company with his father, Albert.

With his expertise as an engineer and instinct for style and design Gerhard E. Jörger set new standards from 1965: Future-oriented, he combined the highest level of craftsmanship and technical quality with special, aesthetic demands. The managing director Oliver Jörger follows this tradition and shapes the modern style of Jörger.



Albert Jörger sen.



Bernhard Jörger



Albert Jörger jun.



Gerhard E. Jörger



Höchste Qualität für außergewöhnliche Ansprüche

HIGHEST QUALITY FOR EXCEPTIONAL DEMANDS



Edelste Materialien kommen in der Produktion aller Jörger-Armaturen und der im Design abgestimmten Accessoires zum Einsatz. Als Rohstoff dient ein hochwertiges, speziell legiertes Messing, das mit modernster Technik in eigener Manufaktur bearbeitet wird.

Die Kunst des präzisen Schleifens und Polierens ist der Garant für eine edle Optik. Mit größter Sorgfalt erfolgt die Bearbeitung der Oberflächen zumeist in reiner Handarbeit. Vom ersten bis zum letzten Arbeitsschritt legt die Design-Manufaktur Jörger kompromisslos Wert auf höchste Qualität. Made in Germany.

Qualitätsfaktor Nummer eins ist der Mensch. Unsere Mitarbeiter sind hoch qualifizierte Spezialisten, die sich der Verantwortung unseren anspruchsvollen Kunden gegenüber jederzeit bewusst sind. Ihre Leidenschaft und ihr handwerkliches Können spiegeln sich im gesamten Portfolio wider.

Only the finest materials are used in the production of Jörger taps and accessories, all in matching design. The raw material is a high quality, specially alloyed brass, which is worked on with the most sophisticated technology, in company own workshops.

The art of precise grinding and polishing is the guarantee for the elegant look. With the utmost care and attention, work on the surfaces is mostly done by hand. From the first step to the very last, the Jörger design manufactory is absolutely committed to delivering only the highest quality. Made in Germany.

However, the most important qualitative factor is, without doubt, the human being. Our employees are highly qualified specialists, who are fully aware of and appreciate the responsibility they bear towards the high expectations of our customers. Their passion and their craftsmanship skills are reflected in all Jörger products.





Als Designer entwickelt Oliver Jörger seit über 20 Jahren persönlich die zeitlose Formgebung weiter und prägt den modernen, geradlinigen Stil auf Basis der überlieferten Gestaltungsideale. Mit Armaturen wie EXAL, VALENCIA, TURN, EMPIRE ROYAL und CRONOS führt er mit kreativer Leidenschaft das einzigartige Jörger Design fort.

Ästhetische Inspirationsquellen sind für den studierten Ingenieur vor allem die Schönheit der Natur, außergewöhnliche Architektur und die Harmonie geometrischer Formen.

Jörger Design entwickelt sich ab und an auch im Dialog und Austausch mit Kunden und Partnern. So gibt es Designlösungen, die im Rahmen privater Projekte auf Kundenwunsch bzw. Designeranfrage entstehen. Jüngstes Beispiel ist ein Schmuckstück der VALENCIA-Kollektion: der schneeweiße Kristall als Pendant zum dekorativen schwarzen Kristall.

As designer, Oliver Jörger has been carrying the timeless design forward for over 20 years and has defined the modern, straight-lined style on the basis of traditional design ideals. He continues the unique Jörger design with creative passion, in fittings such as EXAL, VALENCIA, TURN, EMPIRE ROYAL and CRONOS.

The graduate engineer's aesthetic sources of inspiration include the beauty of nature, extraordinary architecture, and the harmony of geometrical shapes.

Sometimes it is also in exchanges with our customers and business partners that Jörger design develops. Thus there are design solutions created upon customer wish or design request within the scope of a private project. The most recent example for this is the snowy white crystal from the VALENCIA collection that forms the counterpart to the decorative black crystal.

„Jörger Design ist eine Aufgabe,
die mich glücklich macht.“

“JÖRGER DESIGN IS A TASK THAT GIVES ME JOY.”

JC





240
CRONOS



152
CHARLESTON
SQUARE



218
CHARLESTON
ROYAL



292
DELPHI



322
FLORALE
CRYSTAL



194
EMPIRE ROYAL
CRYSTAL



012
VALENCIA



038
EXAL



266
CRONOS CRYSTAL



092
ELEVEN



068
BELLEDOR



130
TURN



174
EMPIRE ROYAL



VALENCIA

Edle Stilverbindungen in Perfektion

ENOBLE STYLE COMBINATIONS, PERFECTLY ENTWINED

Für die Armaturen- und Accessoireserie VALENCIA ließ sich Designer Oliver Jörger von der innovativen und anspruchsvollen Innenausstattung moderner Luxusautos inspirieren. Der eindrucksvolle schwarze Kristall verleiht der Serie eine luxuriöse und glanzvolle Gestalt. Die glatte Oberfläche in Kombination mit einer detaillierten Riffelung im Industrial Design verkörpert den modernen Charakter. Elegant wirkt der ästhetische Auslauf in zeitloser Form.

It was the innovative and sophisticated interior design of modern, luxury automobiles which inspired designer Oliver Jörger to create the VALENCIA range of fittings and accessories. The impressive black crystal gives the range a luxurious and glamorous appearance. The smooth surface in combination with detailed ribbing, in industrial design, embodies the modern character. The aesthetic outlet – timelessly elegant in its form.





Armaturen und Accessoires in Edelmessing mit weißen Kristallgriffen · Taps and accessories in sunshine with crystal handles in white



Jürger

Glanzvoller Auftritt für VALENCIA in Edelmessing mit weißem Kristall

GLAMOUROUS LOOK FOR VALENCIA IN SUNSHINE WITH WHITE CRYSTAL

JÖRGER
DESIGN 





Armatur mit weißem Kristall und Accessoires in Edelmessing - Tap with white crystal and accessories in sunshine

Das neue Schmuckstück der VALENCIA-Kollektion ist ein schneeweißer, facettierter Kristall, eingefasst in einem Korpus aus edlem Metall mit filigraner Riffelung.

The new jewel in the VALENCIA collection is a snow-white, faceted crystal, framed in a body of sunshine with filigree fluting.

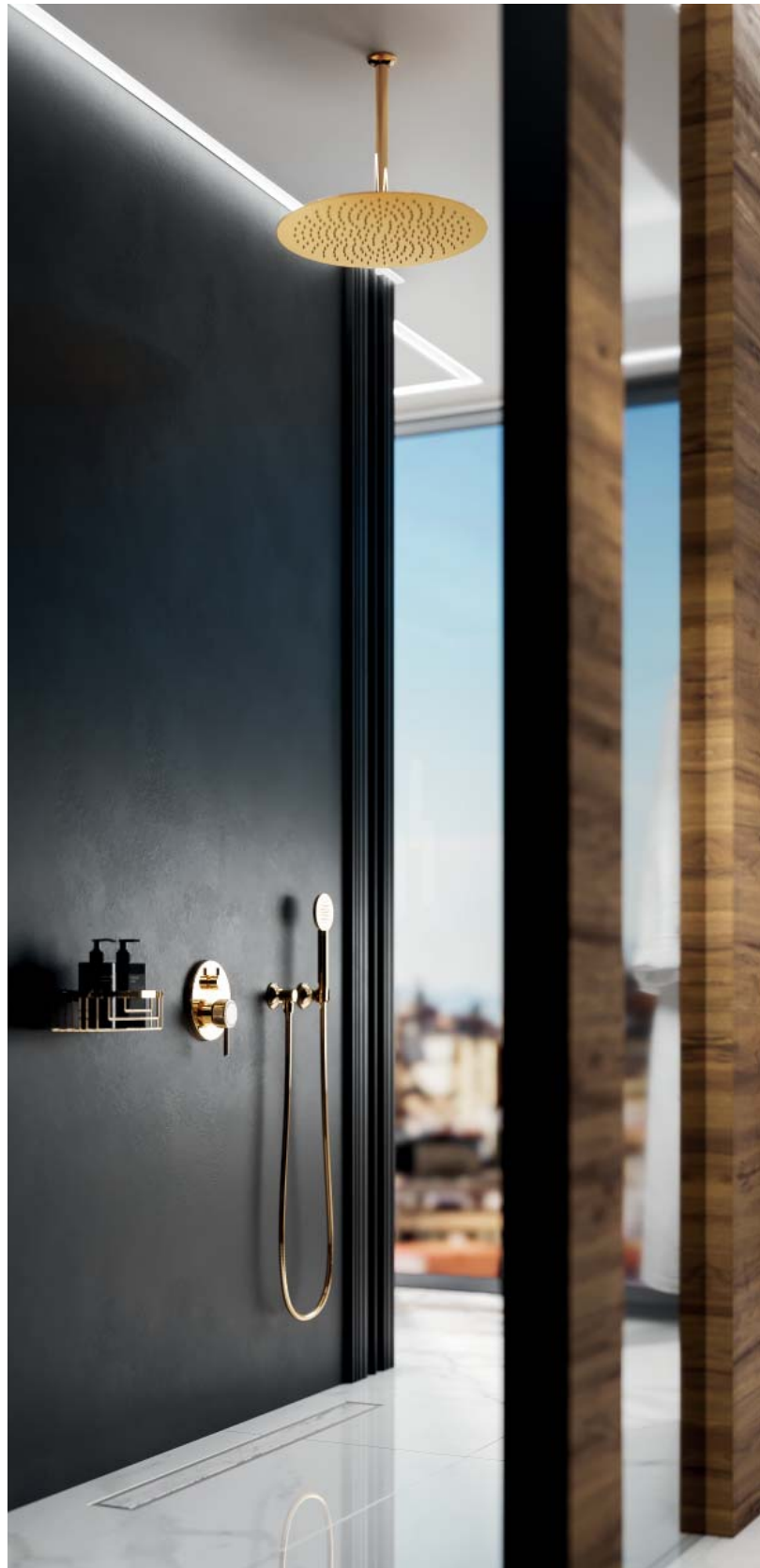

Unterputz 1-Hand Batterie, Schlauchbrausegarnitur, Schwammkorb und Regenbrause in Edelmessing · Concealed single lever mixer, shower combination, sponge basket and rain shower head in sunshine



Unterputz 1-Hand Batterie mit Umstellung und Schlauchbrausegarnitur in Edelmessing · Concealed single lever mixer with diverter and shower combination in sunshine

Oberflächen und Veredelungen – Kristall weiß

SURFACES AND FINISHES – WHITE CRYSTAL



(.000-21) Chrom
chrome



(.095-21) Nerz
mink



(.035-21) Silbernickel
polished nickel



(.040-21) Edelmessing
sunshine



(.011-21) Bronze
bronze



(.096-21) Nerz matt
mink matt



(.036-21) Nickel matt
satin nickel



(.041-21) Edelmessing matt
sunshine matt



(.065-21) Platin
platinum



(.022-21) Roségold
rose gold



(.020-21) Gold
gold



(.092-21) Schwarz matt
black matt



(.066-21) Platin matt
platinum matt



(.023-21) Roségold matt
rose gold matt



(.021-21) Gold matt
gold matt



(.052-21) Weiß matt
white matt

VALENCIA in Roségold – edel und charmant

VALENCIA IN UNIQUE ROSE GOLD FINISH LOOKS CLASSY AND CHARMING





1 638.30.300.xxx-AA



2 638.10.111.xxx-AA



3 638.10.353.xxx-AA



4 638.20.360.xxx-AA + 649.20.360.000



5 638.10.333.xxx-AA



6 638.40.105.xxx-AA



7 638.40.155.xxx-AA



8 638.10.825.xxx-AA + 649.10.970.000



9 638.20.105.xxx

1 | Waschtisch 3-Loch Batterie ½", Ausladung 150 mm · Washbasin 3-hole mixer, spout projection 150 mm 2 | Bidet 1-Hand Batterie · Single lever bidet mixer 3 | Waschtisch 1-Hand Batterie, Ausladung 220 mm · Single lever washbasin mixer, spout projection 220 mm 4 | Wand-Waschtisch 1-Hand Batterie, Ausladung 215 mm · Single lever wall washbasin mixer, spout projection 215 mm 5 | Waschtisch 1-Hand Batterie, Ausladung 150 mm · Single lever washbasin mixer, spout projection 150 mm 6 | 4-Loch Wannenfüll- und Brausebatterie für Standmontage · Tub/shower mixer set, deck mount 7 | 4-Loch Wannenrandkombination ½" · Tub/shower combination ½" 8 | Wannen 1-Hand Batterie für freistehende Montage · Tub/shower mixer set for free standing assembly 9 | Wannenfüll- und Brausebatterie ½" für Aufputzmontage, mit Garnitur · Exposed tub/shower mixer ½", incl. shower set

Weitere Produkte unter www.joerger.de · Further products see www.joerger.de



1-Hand Wand-Waschtisch Batterie in Roségold • *Single lever wall-washbasin mixer in rose gold*



1 638.20.125.xxx-AA + 649.40.360.000



2 638.20.235.xxx-AA + 649.40.360.000



3 638.40.380.xxx-AA + 649.40.360.000



4 638.13.205.xxx



5 638.13.305.xxx



6 638.40.555.xxx-AA + 649.40.555.000



7 638.20.465.xxx-AA



8 638.20.415.xxx-AA



9 638.13.237.xxx + 638.20.237.xxx-AA



10 638.60.432.xxx-AA + 649.20.610.000



11 638.20.250.xxx-AA



12 638.20.200.xxx-AA

1 | 1-Hand Batterie 1/2" für UP-Montage mit Umstellung · Concealed single lever wall mixer 1/2" with diverter 2 | 1-Hand Brausebatterie 1/2" für UP-Montage · Concealed single lever shower mixer 1/2" 3 | Unterputz-Thermostat 1/2" mit Mengenregulierung · Concealed wall thermostat 1/2" with flow control 4 | Schlauchbrausegarnitur · Shower combination 5 | Duschgarnitur mit Duschstange 780 mm · Shower bar set, complete, wall bar 780 mm 6 | Unterputz-Thermostat 3/4" · Concealed wall thermostat 3/4" 7 | Duschesystem mit Aufputz Brausethermostat 1/2", Regenbrause ø 240 mm · Shower system with exposed thermostat 1/2", rainshower ø 240 mm 8 | Duschesystem mit Aufputz Brausebatterie 1/2", Regenbrause ø 240 mm · Shower system with exposed shower mixer 1/2", rainshower ø 240 mm 9 | Hygienebrausegarnitur mit Unterputz 1-Hand Brausebatterie · Ablution spray combination with concealed single lever mixer 10 | Unterputz-Ventil-Modul 3/4" · Concealed wall valve modul 3/4" 11 | Brausethermostat 1/2" für Aufputzmontage · Exposed shower thermostat 1/2" 12 | Brausebatterie für Aufputzmontage 1/2" · Exposed shower mixer 1/2"

Weitere Produkte unter www.joerger.de · Further products see www.joerger.de



Duschkombination und Accessoires in Roségold · Shower combination and accessories in rose gold



Bidet 1-Hand Batterie und Accessoires in Roségold • *Single lever bidet mixer and accessories in rose gold*



1 638.00.006.xxx



2 638.00.007.xxx



3 638.00.014.xxx



5 638.00.017.xxx



4 638.00.031.xxx



6 638.00.030.xxx



7 638.00.016.xxx



8 649.00.414.xxx



9 638.00.046.xxx



10 638.00.000.xxx



11 638.00.001.xxx

1 | Lotionspender · Soap dispenser 2 | Seifenhalter · Soap dish holder 3 | Papierhalter · Toilet paper roll holder 4 | Wannengriff · Tub handle 5 | Seifenhalter, freistehend
 Soap dish holder, free standing 6 | Duschtürgriff, 550 mm · Handle for shower enclosure, 550 mm 7 | Lotionspender, freistehend · Soap dispenser, free standing 8 | Kos-
 metikspiegel, beleuchtet · Cosmetic mirror, illuminated 9 | Glashalter, freistehend · Tumbler holder, free standing 10 | Klosettbürstengarnitur 11 | Klosettbürstengarnitur
 Toilet brush holder set, free standing

Weitere Produkte unter www.joerger.de · Further products see www.joerger.de

Oberflächen und Veredelungen – Kristall schwarz

SURFACES AND FINISHES – BLACK CRYSTAL



(.000-12) Chrom
chrome



(.095-12) Nerz
mink



(.035-12) Silbernickel
polished nickel



(.040-12) Edelmessing
sunshine



(.011-12) Bronze
bronze



(.096-12) Nerz matt
mink matt



(.036-12) Nickel matt
satin nickel



(.041-12) Edelmessing matt
sunshine matt



(.065-12) Platin
platinum



(.022-12) Roségold
rose gold



(.020-12) Gold
gold



(.092-12) Schwarz matt
black matt



(.066-12) Platin matt
platinum matt



(.023-12) Roségold matt
rose gold matt



(.021-12) Gold matt
gold matt



(.052-12) Weiß matt
white matt

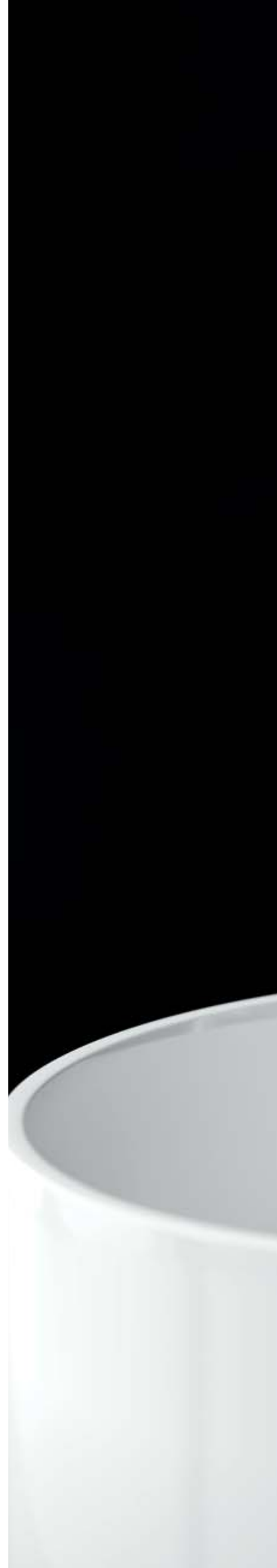



Waschtisch 1-Hand Batterie XXL mit Verlängerung in Silbernickel
Single lever washbasin mixer XXL with extension in polished nickel

Das neue VALENCIA-Design feiert stilvoll Premiere

THE NEW VALENCIA DESIGN WILL SEE ITS PREMIERE
IN ONE FINE SPECIMEN OF A BATHROOM

jörger
DESIGN 





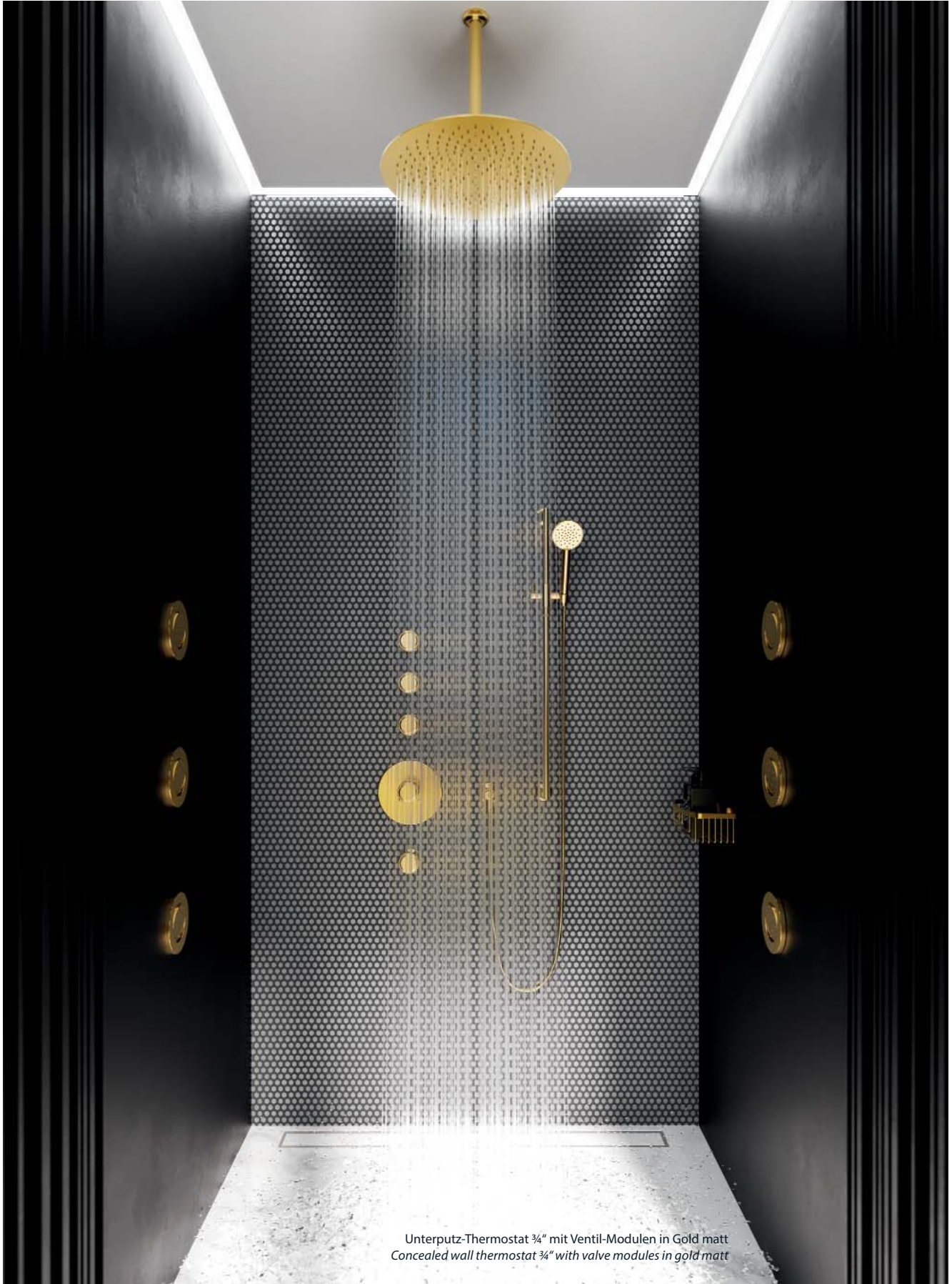

Unterputz-Thermostat $\frac{3}{4}$ " mit Ventil-Modulen in Gold matt
Concealed wall thermostat $\frac{3}{4}$ " with valve modules in gold matt





Edel monochromer Look für VALENCIA in Mattgold mit Metallgriffen

CLASSY MONOCHROME LOOK FOR VALENCIA IN MATT FINISH GOLD WITH METAL HANDLES





Oberflächen und Veredelungen – Metallgriffe

SURFACES AND FINISHES – METAL HANDLES



(.000) Chrom
chrome



(.095) Nerz
mink



(.035) Silbernichel
polished nickel



(.040) Edelmessing
sunshine



(.011) Bronze
bronze



(.096) Nerz matt
mink matt



(.036) Nickel matt
satin nickel



(.041) Edelmessing matt
sunshine matt



(.065) Platin
platinum



(.022) Roségold
rose gold



(.020) Gold
gold



(.092) Schwarz matt
black matt



(.066) Platin matt
platinum matt



(.023) Roségold matt
rose gold matt



(.021) Gold matt
gold matt



(.052) Weiß matt
white matt



Waschtisch 1-Hand Batterie in Gold matt
Single lever waschbasin mixer in gold matt



EXAL

Klare Form in fließendem Design

CLEAR FORM IN FLOWING DESIGN



Fließende Leichtigkeit prägt die Badkollektion EXAL. Die Eleganz des Kranichs im Flug inspirierte Oliver Jörger zu dem modernen Design: Die klare, einfache Form mit dem geschwungenen Auslauf verleiht der Badarmatur ihren dynamischen Stil. Die Vielzahl handgefertigter, exklusiver Oberflächen in glänzender oder matter Ausführung sind die Basis für diverse Designstile. Sie verleihen dem Bad individuellen Charakter und einzigartiges Ambiente – von schlicht bis luxuriös.

Flowing lightness characterises the EXAL bathroom collection. The elegance of the crane in flight inspired Oliver Jörger to create the modern design: the clear, simple shape with the curved spout gives the bathroom fitting its dynamic style. A variety of handcrafted, exclusive surfaces in glossy or matt finishes form the basis for special design styles. They give the bathroom individual character and a uniquely atmospheric ambience – from simple to luxurious.

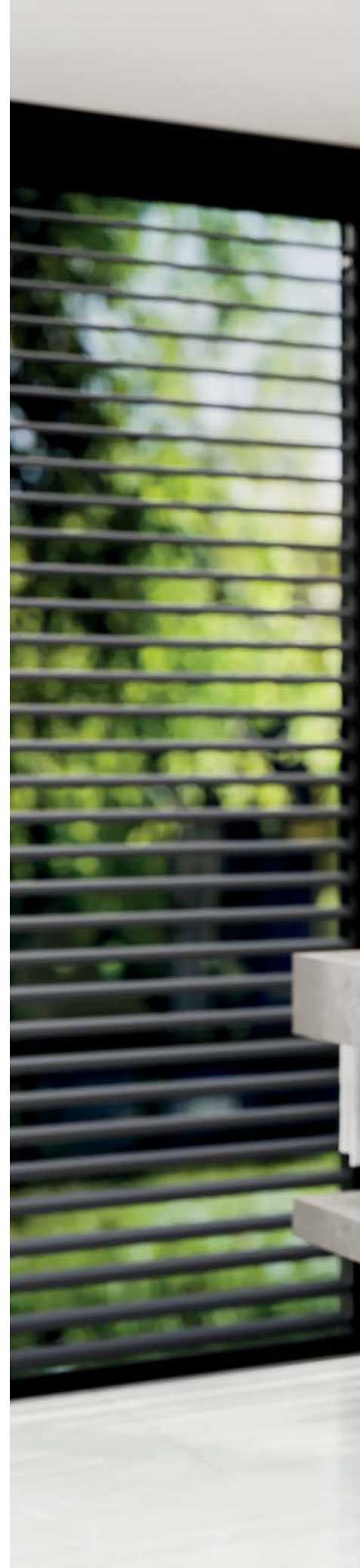







Duschsystem mit Aufputz Brausethermostat, Waschtisch 1-Hand Batterien in Nickel matt
Shower system with exposed thermostat, single lever washbasin mixers in satin nickel



Geradlinigkeit und Dynamik – ein außergewöhnlicher Einklang

STREAMLINED AND DYNAMIC – AN EXTRAORDINARY BALANCE





Der Hebelmischer ist ein Schlüsselement der Badkollektion EXAL und überzeugt durch sein anspruchsvolles Design und seine Funktionalität.

Jörger
DESIGN 

The single lever mixer is the key element of the EXAL bathroom collection and impresses with its sophisticated design and functionality.







Moderner und eleganter Stil auf der Höhe der Zeit

CONTEMPORARY AND ELEGANT STYLE THAT
PERFECTLY MEETS THE TASTE OF THE TIMES



Mehr als eine praktische Alternative: Geradlinig, kompakt und besonders formschön ist die EXAL-Waschtischarmatur für die Wand. Das innovative, seidenmatt schimmernde Finish verleiht den modernen Armaturen und Accessoires eine sehr edle und elegante Ausstrahlung.

More than just a practical alternative: the EXAL wall-mounted washbasin mixer is of straightforward compact style and very beautiful designed. The innovative mink surface in matt finish gives the fittings and accessories a refined and elegant look.



Trendsetter mit klarem
Design und wohnlicher
Ausstrahlung –
EXAL in Nerz matt

TRENDSETTER WITH CLEAR DESIGN AND
HOMELY LOOK – EXAL IN MINK MATT





1 632.10.333.xxx



2 632.10.111.xxx



3 632.10.332.xxx



4 632.20.360.xxx



5 632.12.100.xxx



6 632.20.505.xxx



7 632.20.500.xxx



8 632.20.510.xxx



9 632.20.600.xxx

1 | Waschtisch 1-Hand Batterie, Ausladung 153 mm · *Single lever washbasin mixer, spout projection 153 mm* 2 | Bidet 1-Hand Batterie · *Single lever bidet mixer* 3 | Waschtisch 1-Hand Batterie mit Körperverlängerung, Gesamthöhe 240 mm · *Single lever washbasin mixer with body extension, total height 240 mm* 4 | Wand-Waschtisch 1-Hand Batterie, Ausladung 190 mm · *Single lever wall washbasin mixer, spout projection 190 mm* 5 | Eckventil ½" · *Angle valve ½"* 6 | 1-Hand Aufputz-Wannenfüll- und Brausebatterie ½", mit Garnitur, Ausladung 195 mm · *Single lever exposed tub/shower mixer ½", incl. shower set, spout projection 195 mm* 7 | 1-Hand Aufputz-Wannenfüll- und Brausebatterie ½", mit Garnitur, Ausladung 195 mm · *Single lever exposed tub/shower mixer ½", incl. shower set, spout projection 195 mm* 8 | 1-Hand Aufputz-Wannenfüll- und Brausebatterie ½", ohne Garnitur · *Single lever exposed tub/shower mixer ½", without shower set* 9 | 1-Hand Brausebatterie ½" für Aufputzmontage · *Single lever exposed shower mixer ½"*
 Weitere Produkte unter www.joerger.de | *Further products see www.joerger.de*





Duschkombination und Eckschwammkorb in Nerz matt - Shower combination and corner sponge basket in mink matt



1 632.20.245.xxx + 649.40.360.000



2 615.40.460.xxx + 649.40.360.000



3 632.20.125.xxx + 649.40.360.000

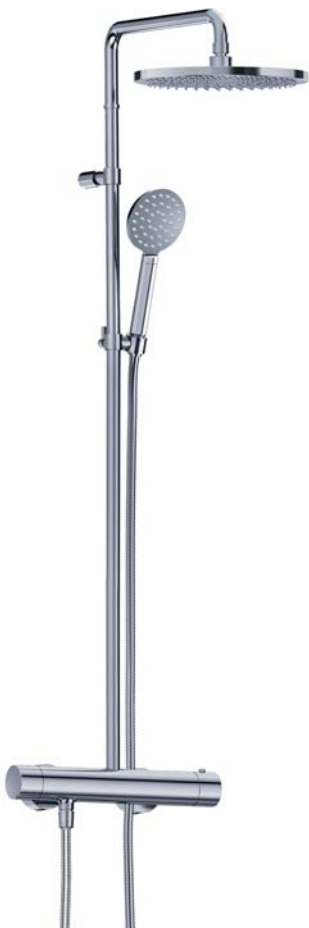

6 632.20.465.xxx



4 632.40.650.xxx + 649.40.600.000



5 634.00.105.xxx



7 632.13.215.xxx



8 632.13.305.xxx

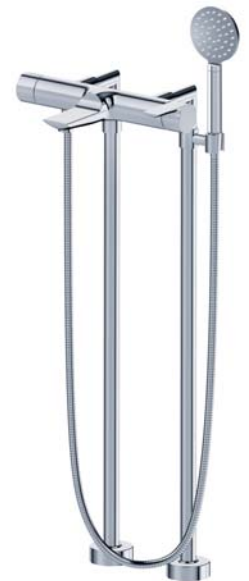

9 632.20.545.xxx + 632.15.260.000

1 | 1-Hand Brausebatterie 1/2" für UP-Montage · *Concealed single lever shower mixer 1/2"* 2 | Unterputz-Thermostat 1/2" · *Concealed wall thermostat 1/2"* 3 | 1-Hand Batterie 1/2" für UP-Montage mit Umstellung · *Concealed single lever wall mixer 1/2" with diverter* 4 | Unterputz 3-Wege Umstellung 1/2" · *Concealed 3-position diverter 1/2"* 5 | Schwammkorb, rechteckig, 260 x 130 mm · *Sponge basket, rectangular, 260 x 130 mm* 6 | Duschesystem mit Aufputz Brausethermostat 1/2", Regenbrause ø 250 mm · *Shower system with exposed thermostat 1/2", rainshower ø 250 mm* 7 | Schlauchbrausegarnitur · *Shower combination* 8 | Duschgarnitur mit Duschstange 800 mm · *Shower bar set, complete, wall bar 800 mm* 9 | 1-Hand Wannenfüll- und Brausebatterie für Standrohrmontage · *Single lever tub/shower mixer for supply pipes*

Weitere Produkte unter www.joerger.de | *Further products see www.joerger.de*



1 649.13.885.xxx



2 615.40.555.xxx +
649.40.555.000



3 632.40.380.xxx + 649.40.360.000



4 632.60.432.xxx +
649.20.610.000



6 634.00.106.xxx



7 632.20.660.xxx



5 649.13.519.xxx



8 632.13.210.xxx



9 632.13.300.xxx



10 632.20.540.xxx +
632.15.260.000

1 | Regenbrause 1/2", ø 250 mm · Rain shower head 1/2", ø 250 mm 2 | Unterputz-Thermostat 3/4" · Concealed wall thermostat 3/4" 3 | Unterputz-Thermostat 1/2" mit Mengenregulierung · Concealed wall thermostat 1/2" with flow control 4 | Unterputz-Ventil-Modul 3/4" · Concealed wall valve modul 3/4" 5 | Seitenbrause 1/2" · Body spray side shower 1/2" 6 | Eckschwammkorb, 195 x 195 mm · Corner sponge basket, 195 x 195 mm 7 | Duschsystem mit 1-Hand Aufputz Brausebatterie 1/2", Regenbrause ø 250 mm · Shower system with single lever exposed shower mixer 1/2", rainshower ø 250 mm 8 | Schlauchbrausegarnitur · Shower combination 9 | Duschgarnitur mit Duschstange 800 mm · Shower bar set, complete, wall bar 800 mm 10 | 1-Hand Wannenfüll- und Brausebatterie für Standrohrmontage · Single lever tub/shower mixer for supply pipes

Weitere Produkte unter www.joerger.de | Further products see www.joerger.de



Duschsystem mit Aufputz Brausebatterie,
Eckschwammkorb in Nerz matt · Shower system with
exposed shower mixer, corner sponge basket in mink mat





1 632.00.036.xxx



2 632.00.022.xxx



3 623.00.005.xxx



4 632.00.002.xxx



5 632.00.031.xxx



6 632.00.040.xxx



7 632.00.046.xxx



8 632.00.014.xxx



9 632.00.047.xxx



10 632.00.000.xxx



11 632.00.001.xxx

1 | Glashalter · Tumbler holder 2 | Handtuchhaken · Robe hanger 3 | Lotionspender · Soap dispenser 4 | Handtuchhalter · Single towel bar 5 | Wannengriff · Tub handle
6 | Badetuchhalter · Bath towel bar 7 | Glashalter, freistehend · Tumbler holder, free standing 8 | Papierhalter · Toilet paper roll holder 9 | Handtuchring · Towel ring 10 | Klosett-
bürstengarnitur · Toilet brush holder set 11 | Klosettbürstengarnitur, freistehend · Toilet brush holder set, free standing

Weitere Produkte unter www.joerger.de | Further products see www.joerger.de



Glanzvoller Luxus für das moderne Bad mit EXAL in Edelmessing

BRILLIANT LUXURY FOR THE MODERN BATHROOM WITH EXAL IN SUNSHINE



Atemberaubender Luxus, wohin das Auge schaut. Durchgängig ist das Design von EXAL in glänzendem Edelmessing für die zentralen Badbereiche umgesetzt. Echte Glanzpunkte setzen die freistehende Badewannenarmatur und die Duschkombination.

Simply stunning luxury: Throughout, EXAL's design is being implemented in the exclusive finish sunshine for the central bathroom areas. The free-standing bath tub mixer and the shower combination create true highlights.



Unterputz-Thermostat $\frac{3}{4}$ " mit Ventil-Modulen, Schlauchbrausegarnitur, Regenhimmel und Schwammkorb in Edelmessing · Concealed wall thermostat $\frac{3}{4}$ " with valve modules, shower combination, Rain Heaven and sponge basket in sunshine



Purer Luxus im Bad - neu und modern interpretiert von EXAL in Edelmessing

PURE LUXURY IN THE BATHROOM - NEW AND CONTEMPORARY MODERN INTERPRETATION FROM EXAL IN THE EXCLUSIVE FINISH SUNSHINE



Wannenfüll- und Brausebatterie für Standrohrmontage in Edelmessing - *Tub/shower mixer for supply pipes in sunshine*





Oberflächen und Veredelungen

SURFACES AND FINISHES



(.000) Chrom
chrome



(.095) Nerz
mink



(.035) Silbernickel
polished nickel



(.040) Edelmessing
sunshine



(.022) Roségold
rose gold



(.011) Bronze
bronze



(.096) Nerz matt
mink matt



(.036) Nickel matt
satin nickel



(.041) Edelmessing matt
sunshine matt



(.023) Roségold matt
rose gold matt



(.065) Platin
platinum



(.066) Platin matt
platinum matt



(.020) Gold
gold



(.021) Gold matt
gold matt



(.092) Schwarz matt
black matt



(.052) Weiß matt
white matt



(.087) Relief-schwarz
black-relief



(.086) Candyviolett
candy-violett



(.063) Apfelgrün matt
apple green matt



(.093) Orange matt
orange matt



(.082) Rot matt
red matt



(.076) Türkis matt
turquoise matt



(.079) Himmelblau matt
azure matt



(.081) Rosa matt
pink matt



(.091) Gelb matt
yellow matt



Waschtisch 1-Hand Batterie in Nickel matt
Single lever washbasin mixer in satin nickel

BELLEDOR

Erlesenes Porzellan in voller Blüte

EXQUISITE PORCELAIN IN FULL BLOOM



FÜRSTENBERG

1747



Klassische Eleganz ist seit jeher zeitlos in ihrer Ästhetik. Der edle und wertvolle Charakter von Porzellan inspirierte Oliver Jörger zur eleganten Badkollektion BELLEDOR.

Die Kollektion erinnert an die einzigartige Kostbarkeit und außergewöhnliche Zeitlosigkeit, die seit Jahrhunderten in dem erlesenen, von Hand bearbeiteten Material liegen. Zart und anmutig, dabei gleichzeitig von erstaunlicher Härte, schenkt das weiße Gold der Porzellanmanufaktur FÜRSTENBERG dem Badezimmer eine erhabene Wertigkeit.

Das Design greift das schmuckvolle Blumendekor in der traditionsreichen Porzellankunst auf.

Stilgerecht abgestimmte Accessoires ergänzen in ihrer herausragenden Gestaltung auf vollkommene Weise die gesamte Serie. Exklusive, handverarbeitete Oberflächen veredeln das zeitgemäße Bad im klassischen Stil.

Aesthetically, classic elegance has always been timeless. The noble character of porcelain inspired Oliver Jörger to create the elegant bathroom collection BELLEDOR.

This collection is reminiscent of the unique preciousness and extraordinary timeliness that has signified this exquisite, handcrafted material for centuries. Delicate and graceful, whilst possessing astonishingly resilient qualities, the white gold from the porcelain manufacturer FÜRSTENBERG gives the bathroom a sublime value.

The design takes up on the ornamental floral decoration, synonymous with the tradition of porcelain art.

Stylishly matched accessories perfectly complement the entire series in their outstanding design. Exclusive, handcrafted surfaces refine the contemporary bathroom perfectly, into a classic style.



Armatur und Accessoires in Chrom
Tap and accessories in chrome

BELLEDOR brilliert im Stil des Neo Art déco – mit Griffen aus schwarzem Porzellan, verziert mit schimmerndem Platin. Besonders edel wirkt der Look in Kombination mit Silbernickel.

BELLEDOR is shining in the style of Neo Art deco – with handles made of black porcelain decorated with shimmering platinum. Looks particularly noble in combination with polished nickel.





4-Loch Wannenfäll- und Brausebatterie in Chrom
Tub/shower 4-hole mixer in chrome



Unterputz-Thermostat $\frac{3}{4}$ " mit Ventil-Modulen in Chrom
Concealed wall thermostat $\frac{3}{4}$ " with valve modules in chrome

BELLEDOR mit Dekorgriffen aus feinem Porzellan von FÜRSTENBERG

BELLEDOR WITH HANDLES MADE OF FINE PORCELAIN BY FÜRSTENBERG





Armaturen und Accessoires in Chrom mit schwarzen Porzellangriffen und Platinbemalung
Taps and accessories in chrome with black porcelain handles and platinum painting





BELLEDOR – klassisch zeitloses Armaturendesign mit eleganten Porzellanangriffen

BELLEDOR – CLASSICALLY TIMELESS TAP DESIGN WITH ELEGANT PORCELAIN HANDLES





1 631.30.300.xxx-AA



2 631.10.100.xxx-AA



3 631.10.300.xxx-AA



5 631.12.100.xxx-AA



4 631.30.360.xxx-AA + 649.30.380.000



6 631.40.155.xxx-AA



7 631.40.105.xxx-AA



8 631.20.155.xxx-AA + 109.10.970.000



9 631.20.105.xxx-AA

1 | Waschtisch 3-Loch Batterie ½", Ausladung 145 mm · Washbasin 3-hole mixer, spout projection 145 mm 2 | Bidet 1-Loch Batterie · Bidet 1-hole mixer 3 | Waschtisch 1-Loch Batterie, Ausladung 105 mm · Washbasin 1-hole mixer, spout projection 105 mm 4 | Wand-Waschtisch 3-Loch Batterie ½", Ausladung ca. 210 mm · Wall washbasin 3-hole mixer, projection approx. 210 mm 5 | Eckventil · Angle Valve 6 | 4-Loch Wannenrandkombination ½" · Tub/shower combination ½" 7 | 4-Loch Wannenfüll- und Brausebatterie, für Standmontage · Tub/shower mixer set deck mount 8 | Wannenfüll- und Brausebatterie für freistehende Montage · Tub/shower mixer set for free standing assembly 9 | Wannenfüll- und Brausebatterie ½" für Aufputzmontage, mit Garnitur · Exposed tub/shower mixer ½", incl. shower set

Weitere Produkte unter www.joerger.de · Further products see www.joerger.de





Freistehende Wannenfüll- und Brausebatterie in Silberrnickel · *Free-standing tub/shower mixer in polished nickel*



1 631.20.125.xxx-AA + 649.40.360.000



2 631.20.235.xxx-AA + 649.40.360.000



3 631.40.380.xxx-AA + 649.40.360.000



4 631.40.555.xxx-AA + 649.40.555.000



5 631.13.205.xxx



6 631.13.315.xxx



7 631.60.432.xxx-AA + 649.20.610.000



8 631.11.100.xxx



12 631.20.415.xxx-AA



9 631.13.237.xxx + 631.20.237.xxx-AA



10 631.20.250.xxx-AA

11 631.20.465.xxx-AA

1 | 1-Hand Wannenfüll- und Brausebatterie 1/2" für UP-Montage · Concealed single lever wall tub and shower mixer 1/2" 2 | 1-Hand Brausebatterie 1/2" für UP-Montage · Concealed single lever shower mixer 1/2" 3 | Unterputz-Thermostat 1/2" mit Mengenregulierung · Concealed wall thermostat 1/2" with flow control 4 | Unterputz-Thermostat 3/4" · Concealed wall thermostat 3/4" 5 | Schlauchbrausegarnitur · Shower combination 6 | Duschgarnitur 1/2" mit Duschstange 795 mm · Shower bar set 1/2", complete, wall bar 795 mm 7 | Unterputz-Ventil-Modul · Concealed wall valve modul 8 | Wand-Wanneneinlauf 1/2" · Tub wall spout 1/2" 9 | Hygienebrausegarnitur mit Unterputz 1-Hand Brausebatterie · Ablution spray combination with concealed single lever mixer 10 | Brausethermostat 1/2" für Aufputzmontage · Exposed shower thermostat 1/2" 11 | Duschsystem mit Aufputz Brausethermostat 1/2", Regenbrause ø 240 mm · Shower system with exposed thermostat 1/2", rainshower ø 240 mm 12 | Duschsystem mit Aufputz Brausebatterie 1/2", Regenbrause ø 240 mm · Shower system with exposed shower mixer 1/2", rainshower ø 240 mm

Weitere Produkte unter www.joerger.de · Further products see www.joerger.de



Armaturen und Accessoires in Silbernickel mit weißen Porzellangriffen und Platinbemalung
Taps and accessories in polished nickel with porcelain handles in white with platinum painting





Armaturen und Accessoires in Silbernickel mit weißen Porzellangriffen und Platinbemalung
 Taps and accessories in polished nickel with porcelain handles in white with platinum painting



Lotionspender und Glashalter in Silbernickel · *Soap dispenser and tumbler holder in polished nickel*



1 631.00.006.xxx



2 631.00.022.xxx



3 631.00.014.xxx



4 631.00.002.xxx



5 631.00.007.xxx



6 631.00.040.xxx



7 631.00.047.xxx



8 631.00.036.xxx



9 631.00.015.xxx



10 631.00.000.xxx

1 | Lotionspender · Soap dispenser 2 | Handtuchhaken, doppelt · Double robe hanger 3 | Papierhalter · Toilet paper roll holder 4 | Handtuchhalter, doppelt · Double towel bar 5 | Seifenhalter · Soap dish holder 6 | Badetuchhalter, 800 mm · Bath towel bar, 800 mm 7 | Handtuchring · Towel ring 8 | Glashalter · Tumbler holder 9 | Reserve-Papierhalter Spare toilet paper roll holder 10 | Klosettbürstengarnitur · Toilet brush holder set

Weitere Produkte unter www.joerger.de · Further products see www.joerger.de



1 631.00.016.xxx



2 631.00.017.xxx



3 649.00.414.xxx



4 631.00.030.xxx



5 631.00.001.xxx



6 634.00.105.xxx



7 634.00.104.xxx



8 631.00.046.xxx



9 631.00.031.xxx

1 | Lotionspender, freistehend · Soap dispenser, free standing 2 | Seifenhalter, freistehend · Soap dish holder, free standing 3 | Kosmetikspiegel, beleuchtet · Cosmetic mirror, incl. lighting 4 | Duschtürgriff ca. 550 mm · Handle for shower enclosure approx. 550 mm 5 | Klosettbürstengarnitur, freistehend · Toilet brush holder set, free standing 6 | Schwammkorb · Sponge basket 7 | Gästehandtuchkorb · Guest towel basket 8 | Glashalter, freistehend · Tumbler holder, free standing 9 | Wannengriff ca. 330 mm · Tub handle approx. 330 mm

Weitere Produkte unter www.joerger.de · Further products see www.joerger.de



Hygienebrausegarnitur und Accessoires in Silbernichel
Ablution spray combination and accessories in polished nickel

Oberflächen und Veredelungen

SURFACES AND FINISHES



(.000) Chrom
chrome



(.095) Nerz
mink



(.035) Silbernichel
polished nickel



(.040) Edelmessing
sunshine



(.011) Bronze
bronze



(.096) Nerz matt
mink matt



(.036) Nickel matt
satin nickel



(.041) Edelmessing matt
sunshine matt



(.065) Platin
platinum



(.022) Roségold
rose gold



(.020) Gold
gold



(.092) Schwarz matt
black matt



(.066) Platin matt
platinum matt



(.023) Roségold matt
rose gold matt



(.021) Gold matt
gold matt



(.052) Weiß matt
white matt





(-31) weiß
white



(-35) schwarz
black



(-32) weiß/gold
white/gold



(-36) schwarz/gold
black/gold



(-33) weiß/platin
white/platinum



(-37) schwarz/platin
black/platinum

Wand-Waschtisch 3-Loch Batterie in Silbernickel
Wall washbasin 3-hole mixer in polished nickel

ELEVEN

Designarmatur für alle

A DESIGN FITTING FOR EVERYONE

Das moderne Design von ELEVEN spielt virtuos mit der Geometrie der Gegensätze und ist inspiriert vom Bild des Bogenschützen. Der Bogen, die Diagonale und die Gerade bilden den Dreiklang der Komposition. Klare, dynamisch abgerundete Formen in spannender Balance mit Geradlinigkeit. Leicht und zierlich gebaut, setzt der Hebelgriff einen aufstrebenden Kontrapunkt. Die Diagonale zitiert den Pfeil. Das Design verleiht der Armatur Leichtigkeit, Dynamik und positive Ausstrahlung.

Inspired by the image of the archer, the modern ELEVEN design is virtuously playing with the geometry of opposites. The bow, the diagonal, and the straight line form the compositional triad here, offering clear, dynamically rounded shapes in an exciting balance with straight lines. Light and delicately constructed, the lever handle provides a rising counterpoint. The diagonal refers to the arrow while the design gives this fitting its light, dynamic and positive appearance.



ELEVEN ist die neue, elfte Badkollektion, die Oliver Jörger selbst entworfen hat. Das spannende Design zieht sich durch das umfangreiche Programm für Waschtisch, Wanne, Dusche und Bidet und findet sich in allen Accessoires umgesetzt. Ob Armaturenmodelle, Oberflächen oder Accessoires – ELEVEN ist von Anfang an breit und vielfältig aufgestellt. So bleiben für die komplette Ausstattung und individuelle Gestaltung von Badezimmer oder Gästebad keine Wünsche offen.

ELEVEN is the new, eleventh bathroom collection designed by Oliver Jörger. Its exciting design can be found throughout the comprehensive range of washbasins, tubs, showers, and bidets, and has been implemented in every accessory. ELEVEN is placed on a pleasantly broad basis from the beginning, with fitting models, finishes, and accessories alike. This leaves nothing to be desired for full equipment and custom design of master or guest bathrooms.





Schönes Design, komfortable Technik

BEAUTIFUL DESIGN, COMFORTABLE TECHNOLOGY



1-Hand Aufputz-Wannenfüll- und Brausebatterie ½" mit Garnitur in Chrom
Single lever exposed tub/shower mixer ½" incl. shower set in chrome



Duschkombination in Chrom - Shower combination in chrome



Schlicht, schlank, formschön

SIMPLE, SLIM, BEAUTIFULLY SHAPED



Wand-Waschtisch 1-Hand Batterie in Chrom
Single lever wall washbasin mixer in chrome



Der Einhebelmischer ist ein Schlüsselement der Kollektion ELEVEN und überzeugt durch hochwertige Verarbeitung, modernes Design und perfekte Technik.

JÖRGER
DESIGN 

The single-lever mixer is a key element of the ELEVEN collection, convincing with high-quality processing, modern design, and perfect technology.







ELEVEN sieht nicht nur exzellent aus. Sie glänzt vor allem auch durch ihre inneren Werte. Das Herzstück des Hebelmischers bildet die hochwertige Keramikkartusche. Die diamantharten, kalkresistenten Keramikscheiben sorgen für leichtgängige Handhabung, Dichtigkeit und Langlebigkeit der Armatur.

ELEVEN not only looks excellent but, first and foremost, stands out with its inner values as well. The lever mixer's core is a high-quality ceramic cartridge. The diamond-hard, scale-resistant ceramic discs ensure smooth operation of a long-lived fitting without any leaks.

Qualität entsteht aus Liebe zum Detail

QUALITY BORN FROM A LOVE OF DETAIL







Moderner und reiner Luxus in XXL – Eleven in Silbernickel

MODERN PURE LUXURY IN XXL MODEL FORMAT – ELEVEN IN POLISHED NICKEL





Die moderne ELEVEN in Silbernickel bringt das Bad auf ein edleres Level

ELEVEN IN POLISHED NICKEL TAKES BATHROOM TO A HIGHER LEVEL



1-Hand Wannenfäll- und Brausebatterie für Standrohrmontage in Silbernickel
Single lever tub/shower mixer for supply pipes in polished nickel





ELEVEN in Silbernickel. Die sanft und angenehm glänzende Oberfläche verleiht den Armaturen und Accessoires eine klare und sehr edle Ausstrahlung. Sehr effektiv dazu wirken die Holzpaneele im angesagten Vintage-Look. Die Materialien harmonisieren perfekt.

ELEVEN in polished nickel. The smooth and beautifully gleaming surface lends the fittings and accessories a clear and very elegant charm. Combined with the wooden panels in the trendy vintage style, the result is truly effective – the materials complement each other perfectly.



Duschsystem mit Aufputz Brausethermostat ½" und Accessoires in Silbernickel
Shower system with exposed thermostat ½" and accessories in polished nickel



Hygienebrausegarnitur mit Unterputz 1-Hand Brausebatterie und Accessoires
in Silbernickel · Hygiene shower fitting with flush mounted 1-hand shower battery
and accessories in polished nickel



1 633.10.333.xxx



2 633.10.334.xxx



3 633.10.332.xxx



4 633.10.335.xxx



5 632.12.100.xxx



6 633.20.360.xxx + 649.20.360.000



8 633.10.111.xxx



7 633.20.600.xxx



9 633.20.505.xxx

1 | Waschtisch 1-Hand Batterie, Ausladung 140 mm · Single lever washbasin mixer, spout projection 140 mm 2 | Waschtisch 1-Hand Batterie ohne Ablaufgarnitur, Ausladung 140 mm · Single lever washbasin mixer without pop-up waste, spout projection 140 mm 3 | Waschtisch 1-Hand Batterie, Gesamthöhe 270 mm · Single lever washbasin mixer, total height 270 mm 4 | Waschtisch 1-Hand Batterie, Ausladung 175 mm · Single lever washbasin mixer, spout projection 175 mm 5 | Eckventil 1/2" · Angle valve 1/2" 6 | Wand-Waschtisch 1-Hand Batterie, Ausladung 190 mm · Single lever wall washbasin mixer, spout projection 190 mm 7 | 1-Hand Brausebatterie 1/2" für Aufputzmontage · Single lever exposed shower mixer 1/2" 8 | Bidet 1-Hand Batterie · Single lever bidet mixer 9 | 1-Hand Aufputz-Wannenfüll- und Brausebatterie 1/2", mit Garnitur, Ausladung 192 mm · Single lever exposed tub/shower mixer 1/2", incl. shower set, spout projection 192 mm

Weitere Produkte unter www.joerger.de | Further products see www.joerger.de

ELEVEN – Modellvielfalt

ELEVEN MODEL DIVERSITY

Den Hebelmischer für den Waschtisch gibt es in drei unterschiedlichen Höhen mit verschieden großer Ausladung – hier in Nickel matt.

The washbasin single lever mixer is available in three different heights with different projections – shown here in satin nickel.







1 633.20.245.xxx + 649.40.360.000



2 615.40.460.xxx + 649.40.360.000



3 633.20.125.xxx + 649.40.360.000



6 632.20.465.xxx



4 632.60.432.xxx + 649.20.610.000



5 634.00.105.xxx



7 632.13.215.xxx



8 632.13.305.xxx



9 633.20.545.xxx + 632.15.260.000

1 | 1-Hand Brausebatterie ½" für UP-Montage · *Concealed single lever shower mixer ½"* 2 | Unterputz-Thermostat ½" · *Concealed wall thermostat ½"* 3 | 1-Hand Batterie ½" für UP-Montage mit Umstellung · *Concealed single lever wall mixer ½" with diverter* 4 | Unterputz-Ventil-Modul ¾" · *Concealed wall valve modul ¾"* 5 | Schwammkorb, rechteckig, 260 x 130 mm · *Sponge basket, rectangular, 260 x 130 mm* 6 | Duschsystem mit Aufputz Brausethermostat ½", Regenbrause ø 240 mm · *Shower system with exposed thermostat ½", rainshower ø 240 mm* 7 | Schlauchbrausegarnitur · *Shower combination* 8 | Duschgarnitur mit Duschstange 800 mm · *Shower bar set, complete, wall bar 800 mm* 9 | 1-Hand Wannenfüll- und Brausebatterie für Standrohrmontage · *Single lever tub/shower mixer for supply pipes*

Weitere Produkte unter www.joerger.de | *Further products see www.joerger.de*



1 649.13.885.xxx



2 615.40.555.xxx +
649.40.555.000



3 632.40.380.xxx + 649.40.360.000



4 632.60.432.xxx +
649.20.610.000



6 634.00.106.xxx



5 649.13.519.xxx



7 633.20.660.xxx



8 632.13.210.xxx



9 632.13.300.xxx



10 633.20.540.xxx +
632.15.260.000

1 | Regenbrause 1/2", ø 250 mm · Rain shower head 1/2", ø 250 mm 2 | Unterputz-Thermostat 3/4" · Concealed wall thermostat 3/4" 3 | Unterputz-Thermostat 1/2" mit Mengenregulierung · Concealed wall thermostat 1/2" with flow control 4 | Unterputz-Ventil-Modul 3/4" · Concealed wall valve modul 3/4" 5 | Seitenbrause 1/2" · Body spray side shower 1/2" 6 | Eckschwammkorb, 195 x 195 mm · Corner sponge basket, 195 x 195 mm 7 | Duschsystem mit 1-Hand Aufputz Brausebatterie 1/2", Regenbrause ø 250 mm · Shower system with single lever exposed shower mixer 1/2", rainshower ø 250 mm 8 | Schlauchbrausegarnitur · Shower combination 9 | Duschgarnitur mit Duschstange 800 mm · Shower bar set, complete, wall bar 800 mm 10 | 1-Hand Wannenfüll- und Brausebatterie für Standrohrmontage · Single lever tub/shower mixer for supply pipes

Weitere Produkte unter www.joerger.de | Further products see www.joerger.de



Duschsystem mit Aufputz Brausethermostat in Silbernickel
Shower system with exposed thermostat 1/2" in polished nickel



Glashalter und Seifenhalter, freistehend, in Silbernickel
Freestanding tumbler holder and soap dish holder in polished nickel



1 632.00.036.xxx



2 632.00.022.xxx



3 623.00.005.xxx



4 632.00.002.xxx



5 632.00.031.xxx



6 632.00.040.xxx



7 632.00.046.xxx



8 632.00.014.xxx



9 632.00.047.xxx



10 632.00.000.xxx



11 632.00.001.xxx

1 | Glashalter · Tumbler holder 2 | Handtuchhaken · Robe hanger 3 | Lotionspender · Soap dispenser 4 | Handtuchhalter · Single towel bar 5 | Wannengriff · Tub handle
6 | Badetuchhalter · Bath towel bar 7 | Glashalter, freistehend · Tumbler holder, free standing 8 | Papierhalter · Toilet paper roll holder 9 | Handtuchring · Towel ring 10 | Klosett-
bürstengarnitur · Toilet brush holder set 11 | Klosettbürstengarnitur, freistehend · Toilet brush holder set, free standing

Weitere Produkte unter www.joerger.de | Further products see www.joerger.de





Willkommen in der Wohlfühloase mit ELEVEN in Nerz matt

WELCOME TO BATHROOM WELLNESS OASIS
WITH ELEVEN IN MINK MATT



Bidet 1-Hand Batterie und Accessoires in Nerz matt
Single lever bidet mixer and accessories in mink matt











Wand-Waschtisch 1-Hand Batterie in Nerz matt
Single lever wall washbasin mixer in mink matt



Moderne Eleganz mit ELEVEN in Nerz matt – Die leicht seidenmatt schimmernde Oberfläche lässt Armaturen und Accessoires in einem eleganten Anthrazit erscheinen. Der Farbton erinnert an das Fell des Zobels und wirkt sehr edel. Perfekt dazu sind moderne Wanddesigns, die funktional und wohnlich zugleich sind.

Modern elegance with ELEVEN in mink matt – The slightly silky-matt shimmering surface makes fittings and accessories appear in an elegant anthracite. The shade is reminiscent of the fur of the sable and looks very noble. Perfectly matched are the modern wall designs, which are functional and homely at the same time.



Duschsystem mit Aufputz 1-Hand Brausebatterie ½" und Accessoires in Nerz matt
 Shower system with exposed single lever mixer ½" and accessories in mink matt

Oberflächen und Veredelungen

SURFACES AND FINISHES



(.000) Chrom
chrome



(.095) Nerz
mink



(.035) Silbernichel
polished nickel



(.040) Edelmessing
sunshine



(.022) Roségold
rose gold



(.011) Bronze
bronze



(.096) Nerz matt
mink matt



(.036) Nickel matt
satin nickel



(.041) Edelmessing matt
sunshine matt



(.023) Roségold matt
rose gold matt



(.065) Platin
platinum



(.066) Platin matt
platinum matt



(.020) Gold
gold



(.021) Gold matt
gold matt



(.092) Schwarz matt
black matt



(.052) Weiß matt
white matt



(.082) Rot matt
red matt



(.076) Türkis matt
turquoise matt



(.081) Rosa matt
pink matt



(.063) Apfelgrün matt
apple green matt



(.093) Orange matt
orange matt



(.079) Himmelblau matt
azure matt



(.084) Lila matt
purple matt



(.091) Gelb matt
yellow matt



1-Hand Aufputz-Wannenfüll- und Brausebatterie ½" in Nerz matt, mit Garnitur, Ausladung 192 mm
Single lever exposed tub/shower mixer ½" in mink matt, incl. shower set, spout projection 192 mm

TURN

Dynamisches Design – einzigartig wie wahre Kunst

DYNAMIC DESIGN – UNIQUE LIKE TRUE ART

Die kunstvoll gewundene Form verleiht der Armatur TURN einzigartige Dynamik und skulpturalen Charakter.

Inspiziert vom spektakulären Cayan Tower in Dubai, entwarf Oliver Jörger das preisgekrönte Design: Eindrucksvoll dreht sich der quadratische Körper 90 Grad um die eigene Achse.

The artistically wound form gives the TURN fitting its unique dynamism and sculptural character.

It was a skyscraper, the spectacular Cayan Tower in Dubai that inspired Oliver Jörger to create the award-winning design: the square body turns impressively 90 degrees around its own axis.







TURN in Chrom. Die Optik ist klar und frisch und sehr modern. Die freistehende Wannenfüll- und Brausebatterie sorgt für ein ganz besonderes Badeerlebnis.

TURN in chrome. The look is clear and fresh and very modern. The free-standing bath and shower mixer ensures a very special bathing experience.

jörger
DESIGN 

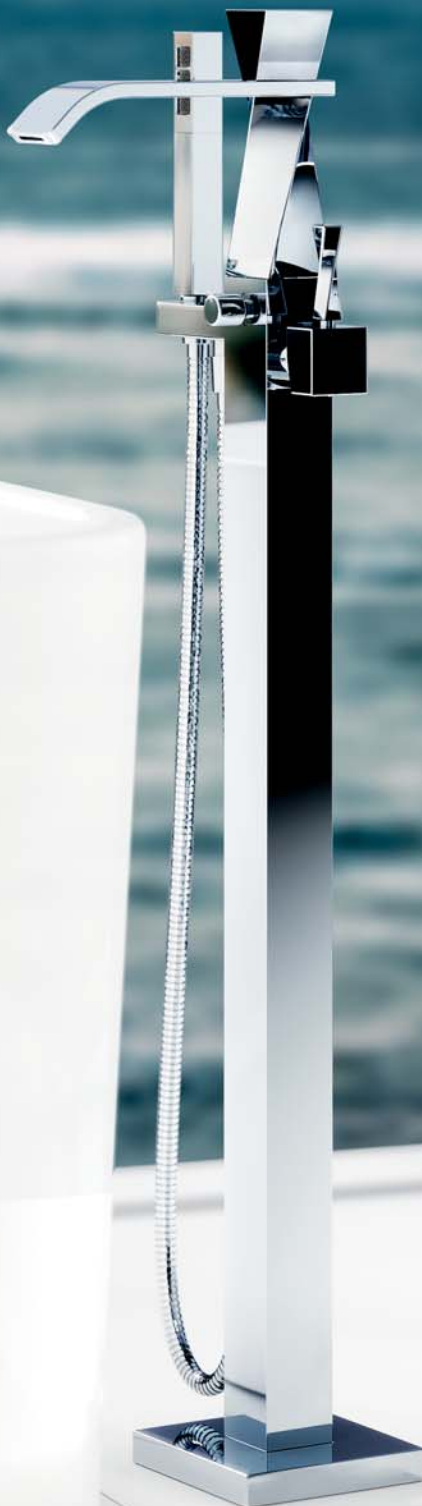



1-Hand Batterie ½" für UP-Montage mit Umstellung in Chrom
Concealed single lever wall mixer ½" with diverter in chrome



Duschkombination und Accessoires in Chrom
Shower combination and accessories in chrome

TURN – geniales Armaturendesign mit perfekt abgestimmten Accessoires

TURN – AWESOME TAP DESIGN WITH PERFECTLY MATCHING ACCESSORIES







Waschtisch 1-Hand Batterie mit Verlängerung, Lotionspender und Wannengriff in Chrom
Single lever washbasin mixer with extension, tub handle and soap dispenser in chrome



Jörger





Waschtisch 1-Hand Batterie, Handtuchhaken in Silbernickel - *Single lever washbasin mixer, robe hanger in polished nickel*

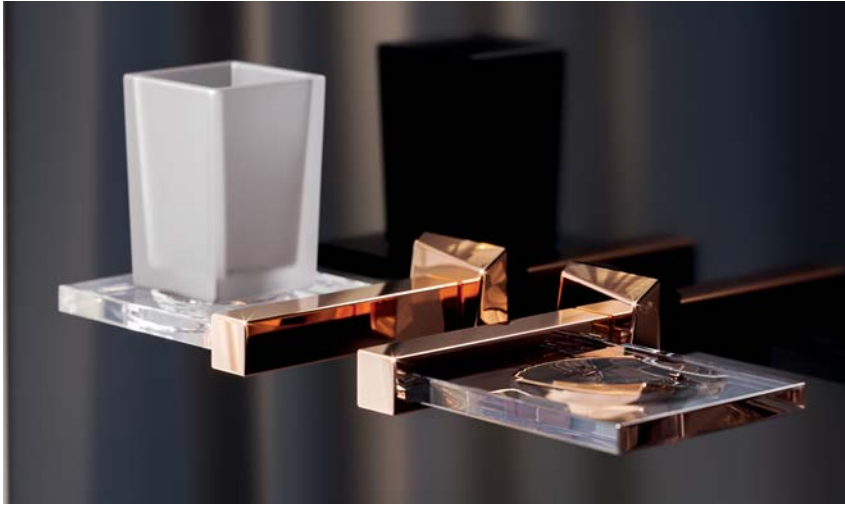

Glashalter, Seifenhalter in Roségold
Tumbler holder, soap dish holder in rose gold

TURN – Oberflächen machen den stilvollen Unterschied

WHAT A STYLISH DIFFERENCE FINISHES MAKE



Papierhalter, 4-Loch Wannenfüll- und Brausebatterie in Nerz
Toilet paper roll holder, tub/shower mixer set in nerz

Jörger
DESIGN 



Waschtisch 1-Hand Batterie in Roségold · *Single lever washbasin mixer in rose gold*



Waschtisch 3-Loch Batterie, Wannengriff in Gold
Washbasin 3-hole mixer, tub handle in gold



1 623.30.300.xxx



2 623.10.111.xxx



3 623.10.333.xxx



4 623.20.366.xxx + 649.20.360.000



5 623.20.360.xxx + 649.20.370.000



6 623.40.100.xxx



7 623.30.360.xxx + 649.30.380.000



8 623.10.332.xxx



9 623.40.150.xxx

1 | Waschtisch 3-Loch Batterie 1/2", Ausladung 150 mm · Washbasin 3-hole mixer 1/2", spout projection 150 mm 2 | Bidet 1-Hand Batterie · Single lever bidet mixer 3 | Waschtisch 1-Hand Batterie, Ausladung 150 mm · Single lever washbasin mixer, spout projection 150 mm 4 | Wand-Waschtisch 1-Hand Batterie, Ausladung 183 - 208 mm · Single lever wall washbasin mixer, spout projection 183 - 208 mm 5 | Wand-Waschtisch 1-Hand Batterie, Ausladung 183 - 208 mm · Single lever wall washbasin mixer, spout projection 183 - 208 mm 6 | 4-Loch Wannenfüll- und Brausebatterie für Standmontage · Tub/shower mixer set, deck mount 7 | Wand-Waschtisch 3-Loch Batterie, Ausladung 190 - 230 mm · Wall washbasin 3-hole mixer, spout projection 190 - 230 mm 8 | Waschtisch 1-Hand Batterie mit Körpverlängerung, Gesamthöhe 390 mm · Single lever washbasin mixer with body extension, total height 390 mm 9 | 4-Loch Wannenrandkombination 1/2" · Tub/shower combination 1/2"

Weitere Produkte unter www.joerger.de · Further products see www.joerger.de



Unterputz-Thermostat $\frac{3}{4}$ " mit Ventil-Modulen, Seitenbrausen, Schlauchbrausegarnitur und Regenhimmel in Chrom
Concealed wall thermostat $\frac{3}{4}$ " with valve modules, body jets, shower combination and Rain Heaven in chrome



1 623.20.125.xxx + 649.40.360.000



2 623.20.235.xxx + 649.40.360.000



3 626.40.380.xxx + 649.40.360.000



8 623.10.820.xxx + 649.10.970.000



4 623.60.432.xxx + 649.20.610.000



5 626.13.237.xxx



6 623.20.237.xxx + 649.20.237.xxx



7 626.40.555.xxx + 649.40.555.000



9 626.11.100.xxx



10 626.13.210.xxx



11 626.13.300.xxx

1 | 1-Hand Batterie ½" für UP-Montage mit Umstellung · *Concealed single lever wall mixer ½" with diverter* 2 | 1-Hand Brausebatterie ½" für UP-Montage · *Concealed single lever shower mixer ½"* 3 | Unterputz-Thermostat ½" mit Mengenregulierung · *Concealed wall thermostat ½" with flow control* 4 | Unterputz-Ventil-Modul ¾" · *Concealed wall valve modul ¾"* 5 + 6 | Hygienebrausegarnitur mit Unterputz 1-Hand Brausebatterie · *Ablution spray combination with concealed single lever mixer* 7 | Unterputz-Thermostat ¾" · *Concealed wall thermostat ¾"* 8 | Wannen 1-Hand Batterie für freistehende Montage · *Tub/shower mixer set for free standing assembly* 9 | Wand-Wanneneinlauf ¾", Ausladung 210 mm · *Tub wall spout ¾", spout projection 210 mm* 10 | Schlauchbrausegarnitur · *Shower combination* 11 | Duschgarnitur mit Duschstange 760 mm · *Shower bar set, complete, wall bar 760 mm*

Weitere Produkte unter www.joerger.de · Further products see www.joerger.de



1 623.00.014.xxx



2 623.00.036.xxx



3 623.00.007.xxx



4 623.00.002.xxx



5 623.00.000.xxx



6 623.00.040.xxx



7 623.00.022.xxx



8 623.00.030.xxx



9 623.00.047.xxx



10 627.00.001.xxx



11 626.00.016.xxx



12 623.00.006.xxx

1 | Papierhalter · Toilet paper roll holder 2 | Glashalter · Tumbler holder 3 | Seifenhalter · Soap dish holder 4 | Handtuchhalter · Single towel bar 5 | Klosettbürstengarnitur Toilet brush holder set 6 | Badetuchhalter, 800 mm · Bath towel bar, 800 mm 7 | Handtuchhaken · Robe hanger 8 | Duschtürgriff, 550 mm · Handle for shower enclosure, 550 mm 9 | Handtuchring · Towel ring 10 | Klosettbürstengarnitur, freistehend · Toilet brush holder set, free standing 11 | Lotionspender, freistehend · Soap dispenser, free standing 12 | Lotionspender · Soap dispenser

Weitere Produkte unter www.joerger.de | Further products see www.joerger.de



Jörge

Oberflächen und Veredelungen

SURFACES AND FINISHES



(.000) Chrom
chrome



(.095) Nerz
mink



(.035) Silbernickel
polished nickel



(.040) Edelmessing
sunshine



(.011) Bronze
bronze



(.096) Nerz matt
mink matt



(.036) Nickel matt
satin nickel



(.041) Edelmessing matt
sunshine matt



(.065) Platin
platinum



(.022) Roségold
rose gold



(.020) Gold
gold



(.092) Schwarz matt
black matt



(.066) Platin matt
platinum matt



(.023) Roségold matt
rose gold matt



(.021) Gold matt
gold matt



(.052) Weiß matt
white matt



Waschtisch 3-Loch Batterie in Chrom · Washbasin 3-hole mixer in chrome

CHARLESTON SQUARE

Geometrie im Einklang

THE HARMONY OF GEOMETRY

CHARLESTON SQUARE besticht durch klares Design, puristische Ästhetik und ein zeitlos elegantes Erscheinungsbild.

Prägend für das Design sind zwei geometrische Grundformen: Runde Elemente verbinden sich mit quadratischen zu einer Gestalt von moderner Eleganz. Verstärkt wird die elegante Wirkung durch den Körper und Auslauf der Armatur.

CHARLESTON SQUARE impresses by its plain design, pure aesthetics and timelessly elegant appearance.

The outstanding design is characterised by two basic geometrical forms: Round elements has been combined with square ones to create a shape of modern elegance. The elegant effect is further increased by body and spout of the fitting.













Traumdesign – puristisch, modern, zeitlos, elegant CHARLESTON SQUARE in Schwarz matt

DREAMFUL BATHROOM DESIGN WITH CHARLESTON SQUARE IN BLACK MATT –
PURISTIC, MODERN, TIMELESS, ELEGANT





Vielfalt wird bei Jörger großgeschrieben. Auch auf Produktebene. Die Kollektion CHARLESTON SQUARE bietet eine Vielzahl von Möglichkeiten, das Bad individuell den eigenen Bedürfnissen und Vorstellungen entsprechend einzurichten.

Diversity is a top priority at Jörger. Also at product level. The CHARLESTON SQUARE collection offers a wide range of options for furnishing the bathroom according to individual needs and ideas.







Armaturen und Accessoires in Schwarz matt - *Fittings and accessories in black matt*



Moderne Eleganz mit sanft femininer Note – CHARLESTON SQUARE in Platin matt

CHARLESTON SQUARE IN PLATINUM MATT – MODERN ELEGANCE WITH SOFTLY FEMININE TOUCH



Jörger
DESIGN





1 634.30.300.xxx



2 634.10.353.xxx



3 634.10.333.xxx

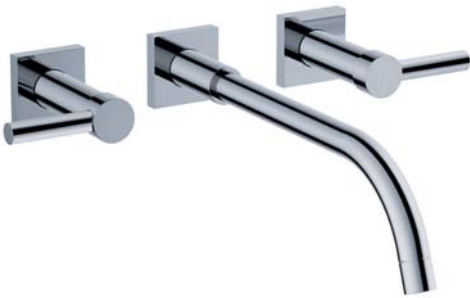

4 634.30.365.xxx + 649.30.380.000



5 626.12.100.xxx



6 634.20.360.xxx + 649.20.360.000



7 634.10.111.xxx



8 634.10.332.xxx



9 634.10.222.xxx

1 | Waschtisch 3-Loch Batterie ½", Ausladung 150 mm · Washbasin 3-hole mixer, spout projection 150 mm 2 | Waschtisch 1-Hand Batterie, Ausladung 240 mm · Single lever washbasin mixer, spout projection 240 mm 3 | Waschtisch 1-Hand Batterie, Ausladung 150 mm · Single lever washbasin mixer, spout projection 150 mm 4 | Wand-Waschtisch 3-Loch Batterie, Ausladung 245 - 270 mm · Wall washbasin 3-hole mixer, spout projection 245 - 270 mm 5 | Eckventil ½" · Angle valve ½" 6 | Wand-Waschtisch 1-Hand Batterie, Ausladung 210 mm · Single lever wall washbasin mixer, spout projection 210 mm 7 | Bidet 1-Hand Batterie · Single lever bidet mixer 8 | Waschtisch 1-Hand Batterie mit Körperverlängerung, Gesamthöhe 440 mm · Single lever washbasin mixer with body extension, total height 440 mm 9 | Handwaschbecken 1-Hand Batterie, Ausladung 85 mm · Mini single lever washbasin mixer, spout projection 85 mm

Weitere Produkte unter www.joerger.de | Further products see www.joerger.de



Wand-Waschtisch 1-Hand Batterie in Weiß matt
Single lever wall washbasin mixer in white matt



1 634.20.505.xxx



2 634.40.105.xxx



4 634.10.854.xxx +
649.10.970.000



5 634.40.155.xxx



3 634.20.515.xxx



8 634.10.825.xxx + 649.10.970.000



7 634.11.100.xxx



6 634.20.605.xxx

1 | 1-Hand Aufputz-Wannenfüll- und Brausebatterie ½", mit Garnitur, Ausladung 190 mm · Single lever exposed tub/shower mixer ½", incl. shower set, spout projection 190 mm
 2 | 4-Loch Wannenfüll- und Brausebatterie für Standmontage · Tub/shower mixer set, deck mount 3 | 1-Hand Aufputz-Wannenfüll- und Brausebatterie ½", ohne Garnitur
 Single lever exposed tub/shower mixer ½" 4 | Waschtisch 1-Hand Batterie für freistehende Montage, Ausladung 240 mm · Single lever washbasin mixer for free standing
 assembly, spout projection 240 mm 5 | 4-Loch Wannenrandkombination ½" · Tub/shower combination ½" 6 | 1-Hand Brausebatterie ½" für Aufputzmontage · Single lever
 exposed shower mixer ½" 7 | Wand-Wanneneinlauf ½", Ausladung 210 mm · Tub wall spout ½", spout projection 210 mm 8 | Wannen 1-Hand Batterie für freistehende Montage
 · Tub/shower mixer set for free standing assembly

Weitere Produkte unter www.joerger.de | Further products see www.joerger.de



Duschkombination und Eckschwammkorb in Schwarz matt
Shower combination and corner sponge basket in black matt



Duschkombination und Regenbrause in Gold
Shower combination and rain shower head in gold



1 634.20.125.xxx + 649.40.360.000



2 634.20.235.xxx + 649.40.360.000



3 634.40.380.xxx + 649.40.360.000



7 634.20.665.xxx

8 634.20.465.xxx



4 634.60.432.xxx + 649.20.610.000



5 634.13.237.xxx



6 634.20.237.xxx + 649.20.237.xxx



9 634.40.555.xxx + 649.40.555.000



10 634.13.215.xxx



11 634.13.305.xxx

1 | 1-Hand Batterie 1/2" für UP-Montage mit Umstellung · *Concealed single lever wall mixer 1/2" with diverter* 2 | 1-Hand Brausebatterie 1/2" für UP-Montage · *Concealed single lever shower mixer 1/2"* 3 | Unterputz-Thermostat 1/2" mit Mengenregulierung · *Concealed wall thermostat 1/2" with flow control* 4 | Unterputz-Ventil-Modul 3/4" · *Concealed wall valve modul 3/4"* 5 | Hygienebrausegarnitur mit Unterputz 1-Hand Brausebatterie · *Ablution spray combination with concealed single lever mixer* 6 | 1-Hand Batterie 1/2" für Hygiene-Brause · *Concealed single lever 1/2" for ablution spray* 7 | Duschsystem mit 1-Hand Aufputz Brausebatterie 1/2", Regenbrause ø 240 mm · *Shower system with single lever exposed shower mixer 1/2", rainshower ø 240 mm* 8 | Duschsystem mit Aufputz Brausethermostat 1/2", Regenbrause ø 240 mm · *Shower system with exposed thermostat 1/2", rainshower ø 240 mm* 9 | Unterputz-Thermostat 3/4" · *Concealed wall thermostat 3/4"* 10 | Schlauchbrausegarnitur · *Shower combination* 11 | Duschgarnitur mit Duschstange 800 mm · *Shower bar set, complete, wall bar 800 mm*

Weitere Produkte unter www.joerger.de · Further products see www.joerger.de



1 634.00.002.xxx



2 634.00.007.xxx



3 634.00.036.xxx



5 634.00.022.xxx



4 634.00.104.xxx



6 634.00.040.xxx



7 634.00.006.xxx

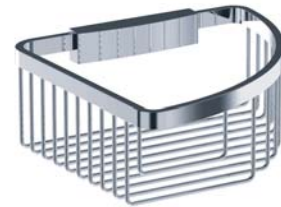

8 634.00.106.xxx



9 649.00.418.xxx



10 634.00.014.xxx



11 634.00.015.xxx



12 634.00.000.xxx

1 | Handtuchhalter · Single towel bar 2 | Seifenhalter · Soap dish holder 3 | Glashalter · Tumbler holder 4 | Gästehandtuchkorb, 260 x 150 x 190 mm · Guest towel basket, 260 x 150 x 190 mm 5 | Handtuchhaken · Robe hanger 6 | Badetuchhalter · Bath towel bar 7 | Lotionspender · Soap dispenser 8 | Eckschwammkorb, 195 x 195 mm Corner sponge basket, 195 x 195 mm 9 | Kosmetikspiegel, beleuchtet · Cosmetic mirror, illuminated 10 | Papierhalter · Toilet paper roll holder 11 | Reserve-Papierhalter Spare toilet paper roll holder 12 | Klosettbürstengarnitur · Toilet brush holder set

Weitere Produkte unter www.joerger.de | Further products see www.joerger.de



Duschkombination und Schwammkorb in Nerz matt
Shower combination and sponge basket in mink matt

Oberflächen und Veredelungen

SURFACES AND FINISHES



(.000) Chrom
chrome



(.095) Nerz
mink



(.035) Silbernickel
polished nickel



(.040) Edelmessing
sunshine



(.011) Bronze
bronze



(.096) Nerz matt
mink matt



(.036) Nickel matt
satin nickel



(.041) Edelmessing matt
sunshine matt



(.065) Platin
platinum



(.022) Roségold
rose gold



(.020) Gold
gold



(.092) Schwarz matt
black matt



(.066) Platin matt
platinum matt



(.023) Roségold matt
rose gold matt



(.021) Gold matt
gold matt



(.052) Weiß matt
white matt





Wand-Waschtisch 1-Hand Batterie und freistehende Accessoires in Edelmessing matt
Single lever wall washbasin mixer and accessories in sunshine matt



EMPIRE ROYAL

Design für das puristische Bad

DESIGN FOR THE PURIST BATHROOM



Das puristisch-minimalistische Design der Serie EMPIRE ROYAL steht in der Tradition ästhetischer Gestaltungsprinzipien und klassischer Designikonen der Moderne. Es verbindet geometrische Formen mit klar definierten Linien. Der Quader bildet das Grundelement der Kreation. Von zeitloser Eleganz ist der formschöne Auslauf der Armatur.

The purist-minimalist design of the EMPIRE ROYAL collection follows the tradition of aesthetic design principles and classic design icons of modernism. It combines geometric shapes with clearly defined lines. The cuboid forms the basic element of the creation. The beautifully shaped spout is of timeless elegance.





Jörger's Farbe des Purismus und Minimalismus ist Nerz. Die galvanische Oberfläche verleiht Armaturen und Accessoires ein elegantes Anthrazit. Der Farbton erinnert an das leicht schimmernde Fell des Zobels.

Jörger's colour of purism and minimalism is mink. Mink is a galvanic surface, which makes fittings and accessories appear in an elegant anthracite. The shade is reminiscent of the slightly shimmering fur of the sable.



Bidet 1-Hand Batterie, Handtuchhaken in Nerz
Single lever bidet mixer, robe hook in mink



Unterputz-Thermostat ¾" mit Ventil-Modulen, Schlauchbrausegarnitur, Regenhimmel und Schwammkorb in Nerz · Concealed wall thermostat ¾" with valve modules, shower combination, Rain Heaven and sponge basket in mink



jörger
DESIGN 





Design-Update und Purismus in noch reinerer Form

DESIGN UPDATE AND PURISM IN AN EVEN PURER FORM





EMPIRE ROYAL Design im Duschbereich: Wie Schmuckstücke glänzen Unterputzthermostat und Ventile in Edelmessing. Besonders im Zusammenspiel mit einer schwarzen Umgebung wird dieses Design zu einem luxuriösen Statement.

EMPIRE ROYAL design in the shower area: like jewellery, the concealed thermostat and valves shine in the exclusive finish sunshine. Especially in combination with a black setting, this design becomes a luxurious statement.



Unterputz 1-Hand Batterie mit Umstellung und Schlauchbrausegarnitur in Edelmessing
Concealed single lever wall mixer with diverter and shower combination in sunshine



Zeitgemäße Designanpassung – ein graziler Bogen und die Griffe ganz auf Quader reduziert

CONTEMPORARY DESIGN ADAPTATION –

AN EVEN MORE GRACEFUL ARCH AND HANDLES REDUCED TO CUBOIDS





Waschtisch 3-Loch Batterie in Silbernickel · Washbasin 3-hole mixer in polished nickel



1 626.10.333.xxx



2 627.10.722.xxx



3 627.10.853.xxx



5 626.12.100.xxx

4 627.20.360.xxx + 649.20.360.000



6 627.10.111.xxx



7 627.10.332.xxx



8 626.30.305.xxx

1 | Waschtisch 1-Hand Batterie, Ausladung 140 mm · *Single lever washbasin mixer, spout projection 140 mm* 2 | Handwaschbecken 1-Hand Batterie, Ausladung 75 mm · *Mini single lever washbasin mixer, spout projection 75 mm* 3 | Waschtisch 1-Hand Batterie, Ausladung 230 mm · *Single lever washbasin mixer, spout projection 230 mm* 4 | Wand-Waschtisch 1-Hand Batterie, Ausladung 210 mm · *Single lever wall washbasin mixer, spout projection 210 mm* 5 | Eckventil 1/2" · *Angle valve 1/2"* 6 | Bidet 1-Hand Batterie · *Single lever bidet mixer* 7 | Waschtisch 1-Hand Batterie mit Körpverlängerung, Gesamthöhe 430 mm · *Single lever washbasin mixer with body extension, total height 430 mm* 8 | Waschtisch 3-Loch Batterie 1/2", Ausladung 140 mm · *Washbasin 3-hole mixer 1/2", spout projection 140 mm*

Weitere Produkte unter www.joerger.de · Further products see www.joerger.de



4-Loch Wannenfüll- und Brausebatterie in Edelmessing · Tub/shower mixer set in sunshine



1 627.30.361.xxx + 649.30.380.000



2 626.20.235.xxx + 649.40.360.000



3 626.40.380.xxx + 649.40.360.000



4 626.40.105.xxx



5 621.60.432.xxx + 649.20.610.000



6 626.13.237.xxx



7 626.20.237.xxx + 649.20.237.xxx



8 626.40.555.xxx + 649.40.555.000



9 626.40.155.xxx



10 626.11.100.xxx



11 626.13.210.xxx



12 626.13.300.xxx

1 | Wand-Waschtisch 3-Loch Batterie, Ausladung 190 - 230 mm · Wall washbasin 3-hole mixer, spout projection 190 - 230 mm 2 | 1-Hand Brausebatterie ½" für UP-Montage · Concealed single lever shower mixer ½" 3 | Unterputz-Thermostat ½" mit Mengenregulierung · Concealed wall thermostat ½" with flow control 4 | 4-Loch Wannenfüll- und Brausebatterie für Standmontage · Tub/shower mixer set, deck mount 5 | Unterputz-Ventil-Modul ¾" · Concealed wall valve modul ¾" 6 | Hygienebrausegarnitur · Ablution spray combination 7 | 1-Hand Batterie ½" für Hygiene-Brause · Concealed single lever mixer ½" for ablution spray 8 | Unterputz-Thermostat ¾" · Concealed wall thermostat ¾" 9 | 4-Loch Wannenrandkombination ½" · Tub/shower combination ½" 10 | Wand-Wanneneinlauf ¾", Ausladung 210 mm · Tub wall spout ¾", spout projection 210 mm 11 | Schlauchbrausegarnitur · Shower combination 12 | Duschgarnitur mit Duschstange 760 mm · Shower bar set, complete, wall bar 760 mm

Weitere Produkte unter www.joerger.de · Further products see www.joerger.de



1 626.20.125.xxx + 649.40.360.000



2 626.10.820.xxx + 649.10.970.000

1 | 1-Hand Batterie ½" für UP-Montage mit Umstellung · *Concealed single lever wall mixer ½" with diverter* 2 | Wannen 1-Hand Batterie für freistehende Montage · *Tub/shower mixer set for free standing assembly*





1 627.00.047.xxx



2 627.00.036.xxx



3 627.00.007.xxx



4 627.00.046.xxx



5 626.00.002.xxx

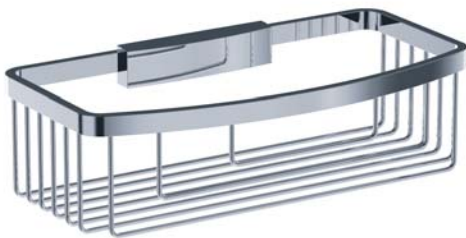

6 634.00.105.xxx



7 626.00.022.xxx



8 626.00.030.xxx



9 627.00.017.xxx



10 626.00.014.xxx



11 626.00.016.xxx



12 626.00.015.xxx



13 627.00.000.xxx

1 | Handtuchring · Towel ring 2 | Glashalter · Tumbler holder 3 | Seifenhalter · Soap dish holder 4 | Glashalter, freistehend · Tumbler holder, free standing 5 | Handtuchhalter · Single towel bar 6 | Schwammkorb, rechteckig, 260 x 130 mm · Sponge basket, rectangular, 260 x 130 mm 7 | Handtuchhaken · Robe hanger 8 | Duschtürgriff, 550 mm · Handle for shower enclosure, 550 mm 9 | Seifenhalter, freistehend · Soap dish holder, free standing 10 | Papierhalter · Toilet paper roll holder 11 | Lotionspender, freistehend · Soap dispenser, free standing 12 | Reserve-Papierhalter · Spare toilet paper roll holder 13 | Klosettbürstengarnitur · Toilet brush holder set

Weitere Produkte unter www.joerger.de | Further products see www.joerger.de



Bidet 1-Hand Batterie und Accessoires in Nerz · *Single lever bidet mixer and accessories in mink*

Oberflächen und Veredelungen

SURFACES AND FINISHES



(.000) Chrom
chrome



(.095) Nerz
mink



(.035) Silbernichel
polished nickel



(.040) Edelmessing
sunshine



(.011) Bronze
bronze



(.096) Nerz matt
mink matt



(.036) Nickel matt
satin nickel



(.041) Edelmessing matt
sunshine matt



(.065) Platin
platinum



(.022) Roségold
rose gold



(.020) Gold
gold



(.092) Schwarz matt
black matt



(.066) Platin matt
platinum matt



(.023) Roségold matt
rose gold matt



(.021) Gold matt
gold matt



(.052) Weiß matt
white matt



Waschtisch 1-Hand Batterie in Chrom · *Single lever washbasin mixer in chrome*

EMPIRE ROYAL CRYSTAL

Royale Akzente mit Kristallen

ROYALE ACCENTS WITH CRYSTALS

Die Pyramidenform stand Pate beim Design von EMPIRE ROYAL CRYSTAL von Oliver Jörger. Die Griffe aus hochwertigen, geschliffenen Kristallen und der schön geschwungene Auslauf der Armatur sind von großer ästhetischer Wirkung und verleihen der modernen, geradlinigen Kollektion ihre einzigartige Anmut.

The pyramid shape was the inspiration for the design of the EMPIRE ROYAL CRYSTAL collection by Oliver Jörger. The handles made of high-quality, polished crystals and the beautifully curved spout of the fitting are of great aesthetic impact and give the modern, straight-lined series its unique grace.







Design, Innovation und Handwerkskunst – schlicht ein Meisterwerk

SIMPLY A MASTERPIECE IN TERMS OF DESIGN, INNOVATION AND CRAFTSMANSHIP





4-Loch Wannrandkombination in Edelmessing · Tub/shower combination in sunshine



1 627.30.360.xxx-AA



2 626.12.100.xxx



3 626.30.300.xxx-AA



4 627.30.100.xxx-AA



5 626.40.150.xxx-AA



6 626.40.100.xxx-AA



7 626.10.820.xxx-AA + 649.10.970.000

1 | Wand-Waschtisch 3-Loch Batterie, Ausladung 190 - 230 mm · Wall washbasin 3-hole mixer, spout projection 190 - 230 mm 2 | Eckventil 1/2" · Angle valve 1/2" 3 | Waschtisch 3-Loch Batterie 1/2", Ausladung 140 mm · Washbasin 3-hole mixer 1/2", spout projection 140 mm 4 | Bidet 3-Loch Batterie 1/2" · Bidet 3-hole mixer 1/2" 5 | 4-Loch Wannenrand-kombination 1/2" · Tub/shower combination 1/2" 6 | 4-Loch Wannenfüll- und Brausebatterie für Standmontage · Tub/shower mixer set, deck mount 7 | Wannen 1-Hand Batterie für freistehende Montage · Tub/shower mixer set for free standing assembly

Weitere Produkte unter www.joerger.de | Further products see www.joerger.de



1 626.40.380.xxx + 649.40.360.000



2 626.40.555.xxx + 649.40.555.000



3 626.40.520.xxx-AA + 649.40.520.000



4 626.40.460.xxx + 649.40.360.000



5 626.60.432.xxx-AA + 649.20.610.000



6 626.13.210.xxx

7 626.13.300.xxx

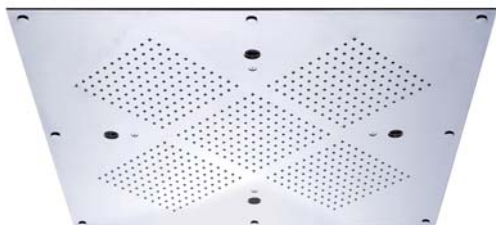

8 649.14.645.xxx



9 626.13.237.xxx

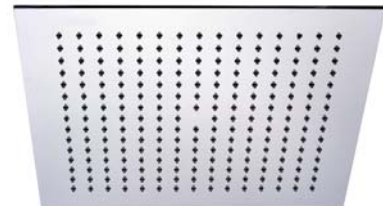

10 649.13.980.xxx

1 | Unterputz-Thermostat ½" mit Mengenregulierung · *Concealed wall thermostat ½" with flow control* **2** | Unterputz-Thermostat ¾" · *Concealed wall thermostat ¾"*
3 | Unterputz-Thermostat ¾" · *Concealed wall thermostat ¾"* **4** | Unterputz-Thermostat ½" · *Concealed wall thermostat ½"* **5** | Unterputz-Ventil-Modul ¾" · *Concealed wall valve modul ¾"* **6** | Schlauchbrausegarnitur · *Shower combination* **7** | Duschgarnitur mit Duschstange 760 mm · *Shower bar set, complete, wall bar 760 mm* **8** | Regenhimmel mit Chromotherapie, 610 x 610 mm · *Rain heaven with chromotherapy, 610 x 610 mm* **9** | Hygienebrausegarnitur · *Ablution spray combination* **10** | Regenbrause ½", 400 x 400 mm · *Rain shower head ½", 400 x 400 mm*

Weitere Produkte unter www.joerger.de | *Further products see www.joerger.de*



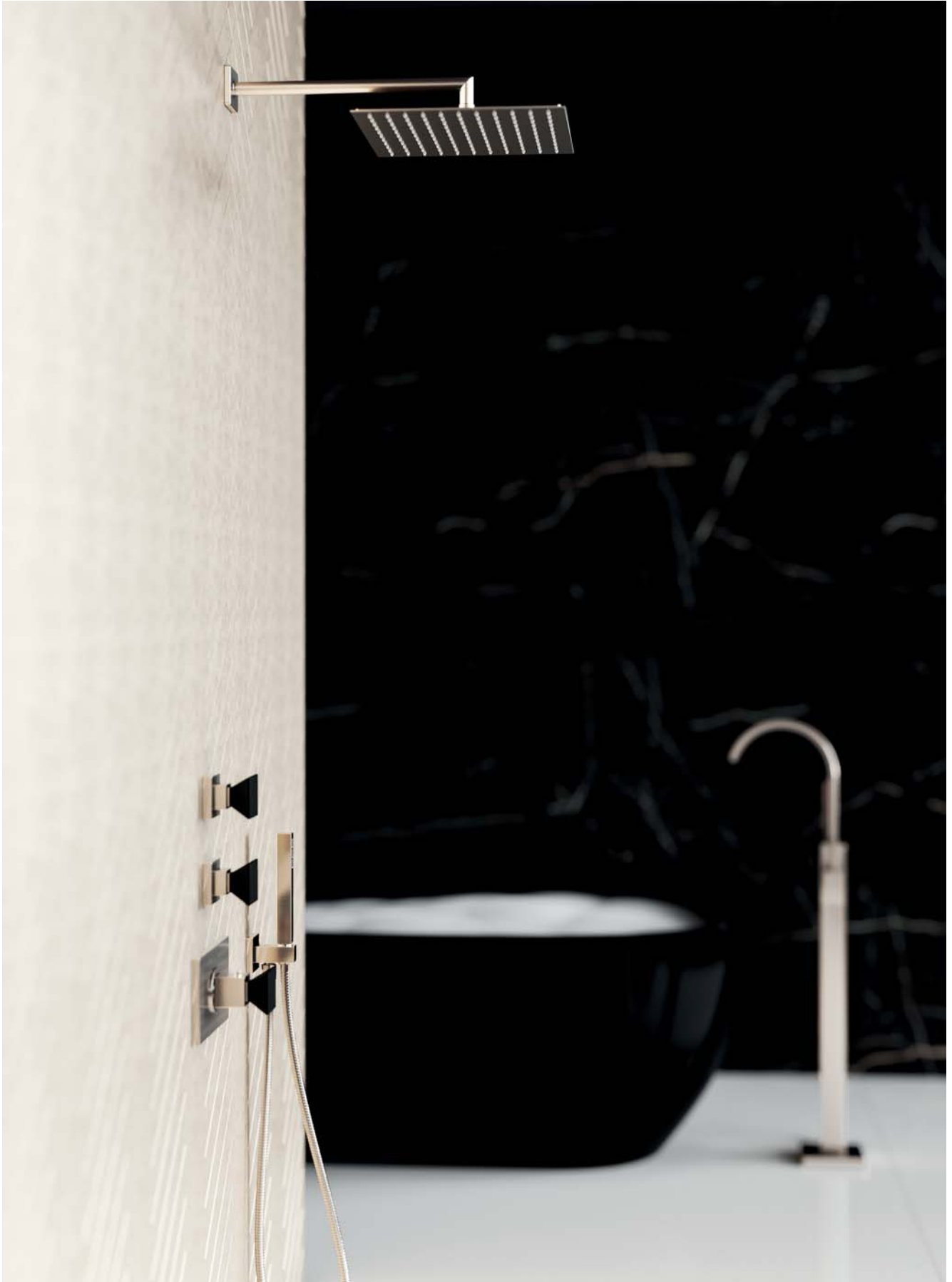





1 627.00.047.xxx



2 627.00.036.xxx



3 627.00.007.xxx



4 627.00.046.xxx



5 626.00.031.xxx

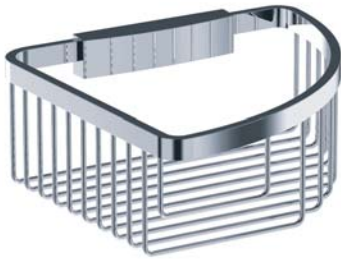

6 634.00.106.xxx



7 626.00.022.xxx



8 626.00.030.xxx



9 627.00.017.xxx



10 626.00.014.xxx



11 626.00.016.xxx



12 626.00.015.xxx



13 627.00.000.xxx

1 | Handtuchring · Towel ring 2 | Glashalter · Tumbler holder 3 | Seifenhalter · Soap dish holder 4 | Glashalter, freistehend · Tumbler holder, free standing 5 | Wannengriff · Tub handle 6 | Eckschwammkorb, 195 x 195 mm · Corner sponge basket, 195 x 195 mm 7 | Handtuchhaken · Robe hanger 8 | Badetuchhalter Bath towel bar 9 | Seifenhalter, freistehend · Soap dish holder, free standing 10 | Papierhalter · Toilet paper roll holder 11 | Lotionspender, freistehend · Soap dispenser, free standing 12 | Reserve-Papierhalter · Spare toilet paper roll holder 13 | Klosettbüstengarnitur · Toilet brush holder set

Weitere Produkte unter www.joerger.de | Further products see www.joerger.de



Puristischer Luxus von großer Eleganz

PURIST LUXURY OF OUTSTANDING ELEGANCE





Armatur mit mattschwarzen Kristallgriffen und Accessoires in Nickel matt · Tap with black matt crystal handles and accessories in satin nickel



EMPIRE ROYAL CRYSTAL – Design für die Sinne

EMPIRE ROYAL CRYSTAL – AESTHETIC DESIGN FOR ALL THE SENSES



JÖRGER
DESIGN 



Je nach Ausführung der Kristalle wird die Anmutung der Armaturen auf unterschiedliche Weise definiert. So stellt EMPIRE ROYAL CRYSTAL in Silbernickel mit Griffen aus klaren Kristallen eine raffinierte Designoption von großer Ästhetik und sehr edler Wirkung dar.

Depending on the design of the crystals, the look of the taps is defined in different ways. For example, EMPIRE ROYAL CRYSTAL in polished nickel with handles made of clear crystal is a sophisticated design option of great aesthetics and authentic luxury.





Hygienebrausegarnitur mit Unterputz 1-Hand Brausebatterie in Silbernickel · Ablution spray combination with concealed single lever mixer in polished nickel





Waschtisch 3-Loch Batterie und freistehende Accessoires in Chrom · Waschbasin 3-hole mixer and freestanding accessories in chrome



Cooler Blickfang in der Dusche.

EMPIRE ROYAL CRYSTAL in Chrom mit Griffen aus mattem Kristall für Unterputz-Thermostat und Ventile.

Real cool eye-catcher in the shower area.

EMPIRE ROYAL CRYSTAL in chrome with handles made of matte crystals for the concealed thermostat and valves.



Unterputz-Thermostat $\frac{3}{4}$ " mit Ventil-Modulen in Chrom
Concealed wall thermostat $\frac{3}{4}$ " with valve modules in chrome

Oberflächen und Veredelungen

SURFACES AND FINISHES



(.000) Chrom
chrome



(.095) Nerz
mink



(.035) Silbernickel
polished nickel



(.040) Edelmessing
sunshine



(.011) Bronze
bronze



(.096) Nerz matt
mink matt



(.036) Nickel matt
satin nickel



(.041) Edelmessing matt
sunshine matt



(.065) Platin
platinum



(.022) Roségold
rose gold



(.020) Gold
gold



(.092) Schwarz matt
black matt



(.066) Platin matt
platinum matt



(.023) Roségold matt
rose gold matt



(.021) Gold matt
gold matt



(.052) Weiß matt
white matt



Accessoires und Armaturen in Chrom mit Griffen in Kristall matt
 Accessories and taps in chrome with handles in crystal matt



(-11) kristallklar
 clear as crystal



(-12) schwarz
 black



(-61) kristall matt
 crystal matt



(-62) schwarz matt
 black matt



CHARLESTON ROYAL

Moderner Designklassiker im Bad

MODERN DESIGN CLASSIC IN THE BATHROOM

CHARLESTON ROYAL formt mit seinem schlichten, klaren Design eine harmonische Zeitlosigkeit im Badezimmer. Als Inspirationsquelle für das Design diente Oliver Jörger der legendäre Bauhaus-Stil in seiner zurückhaltenden, eleganten und funktionalen Ästhetik. Basierend auf der Grundform des Kreises zählt die formschöne, geradlinige Serie zu den zeitlos modernen und minimalistischen Armaturenklassikern im Badezimmer.

With its simple, clear design CHARLESTON ROYAL brings an ideal harmony into the bathroom. Oliver Jörger's source of inspiration for the design has been the legendary Bauhaus style in its restrained, elegant and functional aesthetics. Based on the basic shape of the circle, the elegant, linear collection is one of the timelessly modern mixer classics.





JÖRGER
DESIGN 

Puristisches Design von klassischer Eleganz

PURIST DESIGN OF CLASSIC ELEGANCE



Wannen 1-Hand Batterie für freistehende Montage in Chrom
Tub/shower mixer set for free standing assembly in chrome



Waschtisch 1-Hand Batterie in Chrom · *Single lever washbasin mixer in chrome*



Duschkombination und Schwammkorb in Bronze · Shower combination and sponge basket in bronze



Konsequent folgen die Armaturen-Elemente und die vielfältigen Accessoires der klaren, runden Formensprache in der Gestaltung. Zeitlose Eleganz vermittelt der schlanke, schlichte Bogen, der stilbildend ist für die gesamte Produktpalette für Dusche, Bidet, Badewanne und Waschtisch.

The fixture elements and the wide range of accessories consistently follow the noble, round and reduced form language. The thin, simple curve denotes timeless elegance and forms the basis for the entire range of products for showers, bidets, bathtubs and washbasins.



Lotionspender, Reserve-Papierhalter in Bronze
 Soap dispenser, spare toilet paper roll holder in bronze



Armaturen und Accessoires in Nerz matt · Fittings and accessories in mink matt







Schwarz matt – die trendige Farbe des Purismus

BLACK MATT – THE TRENDY COLOUR OF PURISM







1 619.30.300.xxx



2 619.10.353.xxx



3 619.10.333.xxx



4 619.30.360.xxx + 649.30.380.000



5 632.12.100.xxx



6 619.20.360.xxx + 649.20.360.000



7 619.10.111.xxx



8 619.10.332.xxx



9 619.10.222.xxx

1 | Waschtisch 3-Loch Batterie ½", Ausladung 150 mm · Washbasin 3-hole mixer, spout projection 150 mm 2 | Waschtisch 1-Hand Batterie, Ausladung 240 mm · Single lever washbasin mixer, spout projection 240 mm 3 | Waschtisch 1-Hand Batterie, Ausladung 150 mm · Single lever washbasin mixer, spout projection 150 mm 4 | Wand-Waschtisch 3-Loch Batterie, Ausladung 175 - 200 mm · Wall washbasin 3-hole mixer, spout projection 175 - 200 mm 5 | Eckventil ½" · Angle valve ½" 6 | Wand-Waschtisch 1-Hand Batterie, Ausladung 210 mm · Single lever wall washbasin mixer, spout projection 210 mm 7 | Bidet 1-Hand Batterie · Single lever bidet mixer 8 | Waschtisch 1-Hand Batterie mit Körperverlängerung, Gesamthöhe 440 mm · Single lever washbasin mixer with body extension, total height 440 mm 9 | Handwaschbecken 1-Hand Batterie, Ausladung 85 mm · Mini single lever washbasin mixer, spout projection 85 mm

Weitere Produkte unter www.joerger.de | Further products see www.joerger.de



Waschtisch 1-Hand Batterien, Accessoires in Platin matt - Single lever washbasin mixers, accessories in platinum matt



1 619.20.505.xxx



2 619.40.105.xxx



4 619.10.854.xxx +
649.10.970.000



5 615.40.155.xxx



3 619.30.445.xxx

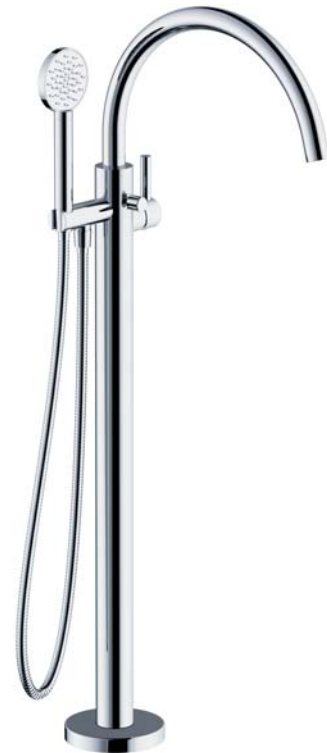

8 619.10.825.xxx + 649.10.970.000



7 619.11.100.xxx



6 619.20.605.xxx

1 | 1-Hand Aufputz-Wannenfüll- und Brausebatterie ½", mit Garnitur, Ausladung 190 mm · Single lever exposed tub/shower mixer ½", incl. shower set, spout projection 190 mm
 2 | 4-Loch Wannenfüll- und Brausebatterie für Standmontage · Tub/shower mixer set, deck mount 3 | 3-Loch Wannenfüll- und Brausebatterie ½" · 3-hole tub/shower mixer set ½" 4 | Waschtisch 1-Hand Batterie für freistehende Montage, Ausladung 240 mm · Single lever washbasin mixer for free standing assembly, spout projection 240 mm
 5 | 4-Loch Wannenrandkombination ½" · Tub/shower combination ½" 6 | 1-Hand Brausebatterie ½" für Aufputzmontage · Single lever exposed shower mixer ½" 7 | Wand-Wanneneinlauf ½", Ausladung 210 mm · Tub wall spout ½", spout projection 210 mm 8 | Wannen 1-Hand Batterie für freistehende Montage · Tub/shower mixer set for free standing assembly

Weitere Produkte unter www.joerger.de | Further products see www.joerger.de



Wannenfüll- und Brausearmatur, freistehend in Platin matt · Tub/shower mixer free-standing in platinum matt



Duschkombination in Roségold · Shower combination in rose gold



1 615.20.125.xxx + 649.40.360.000



2 615.20.235.xxx + 649.40.360.000



3 615.40.380.xxx + 649.40.360.000



7 619.20.665.xxx



8 632.20.465.xxx



4 615.60.432.xxx + 649.20.610.000



5 619.13.237.xxx



6 615.20.237.xxx + 649.20.237.xxx



9 615.40.555.xxx + 649.40.555.000



10 632.13.215.xxx



11 632.13.305.xxx

1 | 1-Hand Batterie ½" für UP-Montage mit Umstellung · *Concealed single lever wall mixer ½" with diverter* 2 | 1-Hand Brausebatterie ½" für UP-Montage · *Concealed single lever shower mixer ½"* 3 | Unterputz-Thermostat ½" mit Mengenregulierung · *Concealed wall thermostat ½" with flow control* 4 | Unterputz-Ventil-Modul ¾" · *Concealed wall valve modul ¾"* 5 | Hygienebrausegarnitur · *Ablution spray combination* 6 | 1-Hand Batterie ½" für Hygiene-Brause · *Concealed single lever ½" for ablution spray* 7 | Duschsystem mit 1-Hand Aufputz Brausebatterie ½", Regenbrause ø 240 mm · *Shower system with single lever exposed shower mixer ½", rainshower ø 240 mm* 8 | Duschsystem mit Aufputz Brausethermostat ½", Regenbrause ø 240 mm · *Shower system with exposed thermostat ½", rainshower ø 240 mm* 9 | Unterputz-Thermostat ¾" · *Concealed wall thermostat ¾"* 10 | Schlauchbrausegarnitur · *Shower combination* 11 | Duschgarnitur mit Duschstange 800 mm · *Shower bar set, complete, wall bar 800 mm*

Weitere Produkte unter www.joerger.de · *Further products see www.joerger.de*



1 632.00.005.xxx



2 632.00.017.xxx



3 632.00.036.xxx



5 632.00.022.xxx



4 632.00.004.xxx



7 632.00.016.xxx



6 632.00.040.xxx



8 632.00.031.xxx



9 649.00.414.xxx



10 632.00.001.xxx



11 632.00.015.xxx



12 632.00.000.xxx

1 | Lotionspender · Soap dispenser 2 | Seifenhalter, freistehend · Soap dish holder, free standing 3 | Glashalter · Tumbler holder 4 | Handtuchhalter · Single towel bar 5 | Handtuchhaken · Robe hanger 6 | Badetuchhalter · Bath towel bar 7 | Lotionspender, freistehend · Soap dispenser, free standing 8 | Wannengriff · Tub handle 9 | Kosmetikspiegel, beleuchtet · Cosmetic mirror, illuminated 10 | Klosettbürstengarnitur, freistehend · Toilet brush holder set, free standing 11 | Reserve-Papierhalter Spare toilet paper roll holder 12 | Klosettbürstengarnitur · Toilet brush holder set

Weitere Produkte unter www.joerger.de | Further products see www.joerger.de



Duschkombination in Weiß matt · Shower combination in white matt

Oberflächen und Veredelungen

SURFACES AND FINISHES



(.000) Chrom
chrome



(.095) Nerz
mink



(.035) Silbernichel
polished nickel



(.040) Edelmessing
sunshine



(.011) Bronze
bronze



(.096) Nerz matt
mink matt



(.036) Nickel matt
satin nickel



(.041) Edelmessing matt
sunshine matt



(.065) Platin
platinum



(.022) Roségold
rose gold



(.020) Gold
gold



(.092) Schwarz matt
black matt



(.066) Platin matt
platinum matt



(.023) Roségold matt
rose gold matt



(.021) Gold matt
gold matt



(.052) Weiß matt
white matt





Waschtisch 3-Loch Batterie in Edelmessing matt - Washbasin 3-hole mixer in sunshine matt

CRONOS

Design für die Ewigkeit

DESIGN MADE FOR ETERNITY

Manchmal sind es die kleinen Dinge des Alltags, die etwas Besonderes hervorbringen. Es war die Uhr des Großvaters, genauer gesagt die Krone dieser historischen Taschenuhr, die Oliver Jörger zum modernen Design von CRONOS inspiriert hat.

Klarheit und klassische Eleganz prägen die stilvolle Kollektion. Wie Kanneluren an antiken Säulen zieren feine Linien die Oberfläche der Armatur. Die weiche Form des Körpers gleicht die strenge Geradlinigkeit aus.

Sometimes it's the little things in everyday life that bring forth something special. It was the Grandfather's watch, or more precisely, the crown of this historic pocket watch, that inspired Oliver Jörger to create the modern design of CRONOS.

Clarity and classical elegance characterise this stylish collection. Like fluting on ancient pillars, fine lines grace the surface of the fixture. The soft shape of the body offsets the strict linear feel.







Die freistehende Wannenarmatur in Roségold aus der Serie CRONOS strahlt feminine Eleganz mit dezentem Luxus aus. Zusammen mit der trendigen, weißen Badewanne setzt das Edelfinish stilvolle, leicht romantische Akzente im Bad.

The freestanding bath mixer in rose gold from the CRONOS series exudes a slightly feminine elegance and understated luxury. Together with the trendy white bathtub, the fine finish sets stylish, slightly romantic accents in the bathroom.

Poesie in Roségold – Das Edelfinish strahlt feminine Eleganz und dezenten Luxus aus

POETRY IN ROSE GOLD – THE FINE FINISH
EXUDES A SLIGHTLY FEMININE ELEGANCE
AND UNDERSTATED LUXURY



Waschtisch 3-Loch Batterie in Roségold
Washbasin 3-hole mixer in rose gold



Handwerk und Kunstfertigkeit in Reinkultur

CRONOS IN POLISHED NICKEL – ARTISTRY IN CRAFTSMANSHIP THAT CANNOT BE SURPASSED





Unterputz-Thermostat ½" mit Ventil-Modulen und Accessoires in Silbernickel
Concealed wall thermostat ½" with valve modules and accessories in polished nickel

Jede Armatur ist mit den Varianten „Hebelgriff“ und „Kreuzgriff“ kombinierbar.

Each tap is available with the handle styles "lever" or "cross".



Kreuzgriff

Cross handle



Hebelgriff

Lever handle



1 637.30.300.xxx



2 637.10.100.xxx



3 637.30.360.xxx + 649.30.380.000



4 637.20.102.xxx



5 637.12.100.xxx



6 637.40.102.xxx



7 637.40.152.xxx

1 | Waschtisch 3-Loch Batterie ½", Ausladung 160 mm · Washbasin 3-hole mixer, spout projection 160 mm 2 | Bidet 1-Loch Batterie · Bidet 1-hole mixer 3 | Wand-Waschtisch 3-Loch Batterie, Ausladung 190 - 215 mm · Wall washbasin 3-hole mixer, spout projection 190 - 215 mm 4 | Wannenfüll- und Brausebatterie ½" für Aufputzmontage, mit Garnitur · Exposed tub/shower mixer ½", incl. shower set 5 | Eckventil ½" · Angle valve ½" 6 | 4-Loch Wannenfüll- und Brausebatterie für Standmontage · Tub/shower mixer set, deck mount 7 | 4-Loch Wannenrandkombination ½" · Tub/shower combination ½"

Weitere Produkte unter www.joerger.de · Further products see www.joerger.de



Waschtisch 3-Loch Batterie in Silbernickel
Washbasin 3-hole mixer in polished nickel



Waschtisch 3-Loch Batterie in Gold
Washbasin 3-hole mixer in gold



1 637.30.305.xxx



2 637.10.105.xxx



3 637.30.365.xxx



4 637.20.107.xxx



5 637.12.105.xxx



6 637.40.157.xxx



7 637.40.107.xxx



8 637.11.100.xxx

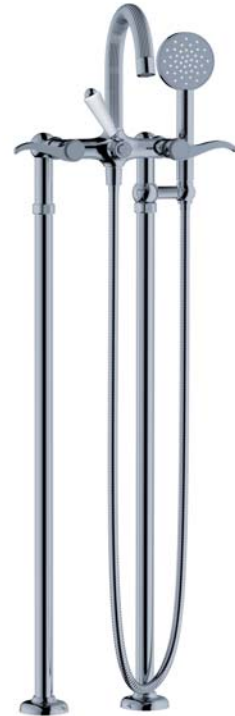

9 637.20.147.xxx + 600.15.260.xxx

1 | Waschtisch 3-Loch Batterie ½", Ausladung 160 mm · Washbasin 3-hole mixer, spout projection 160 mm 2 | Bidet 1-Loch Batterie · Bidet 1-hole mixer 3 | Wand-Waschtisch 3-Loch Batterie, Ausladung 190 - 215 mm · Wall washbasin 3-hole mixer, spout projection 190 - 215 mm 4 | Wannenfüll- und Brausebatterie ½" für Aufputzmontage, mit Garnitur · Exposed tub/shower mixer ½", incl. shower set 5 | Eckventil ½" · Angle valve ½" 6 | 4-Loch Wannenrandkombination ½" · Tub/shower combination ½" 7 | 4-Loch Wannenfüll- und Brausebatterie für Standmontage · Tub/shower mixer set, deck mount 8 | Wand-Wannenreinlauf ½" · Tub wall spout ½" 9 | Wannenfüll- und Brausebatterie für Standrohrmontage · Tub/shower mixer for supply pipes

Weitere Produkte unter www.joerger.de · Further products see www.joerger.de



Wannenfüll- und Brausebatterie für Standrohrmontage in Nerz
Tub/shower mixer for supply pipes in mink

Die innovative Beschichtung namens Nerz schafft durch die schön glänzende Farbe Anthrazit ein ausdrucksstarkes Badambiente mit edlem Flair. CRONOS wirkt in dieser Designvariante besonders markant und extravagant.

The innovative coating called mink creates an expressive bathroom ambience with noble flair thanks to its beautifully shining anthracite colour. CRONOS looks particularly striking and extravagant in this design option.



Wannenfüll- und Brausebatterie für Standrohrmontage in Nerz
Tub/shower mixer for supply pipes in mink



Waschtisch 3-Loch Batterie in Nerz
Washbasin 3-hole mixer in mink

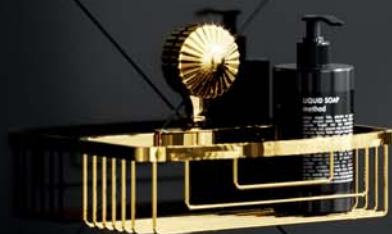
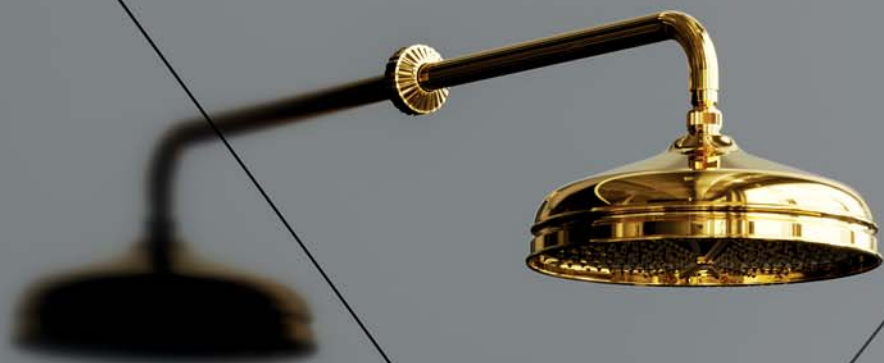

Unterputz-Thermostat $\frac{3}{4}$ " mit Ventil-Modulen in Gold
Concealed wall thermostat $\frac{3}{4}$ " with valve modules in gold



3 637.20.412.xxx



1 637.20.200.xxx



2 637.20.205.xxx



5 637.20.467.xxx

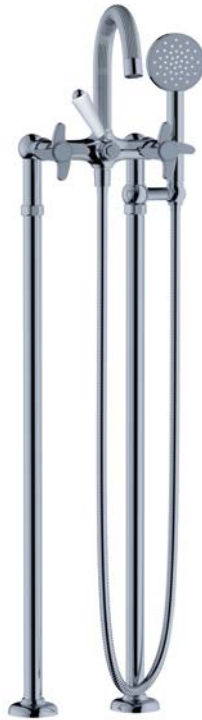

4 637.20.142.xxx +
600.15.260.xxx



6 637.00.106.xxx



7 637.20.250.xxx



8 637.00.105.xxx

1 | Brausebatterie für Aufputzmontage ½" · Exposed shower mixer ½" 2 | Brausebatterie für Aufputzmontage ½" · Exposed shower mixer ½" 3 | Duschesystem mit Aufputz Brausebatterie ½", Regenbrause ø 200 mm · Shower system with exposed shower mixer ½", rainshower ø 200 mm 4 | Wannenfüll- und Brausebatterie für Standrohrmontage Tub/shower mixer for supply pipes 5 | Duschesystem mit Aufputz Brausethermostat ½", Regenbrause ø 200 mm · Shower system with exposed thermostat ½", rainshower ø 200 mm 6 | Eckschwammkorb, 195 x 195 mm · Corner sponge basket, 195 x 195mm 7 | Brausethermostat ½" für Aufputzmontage · Exposed shower thermostat ½" 8 | Schwammkorb, rechteckig, 260 x 130 mm · Sponge basket, rectangular, 260 x 130 mm

Weitere Produkte unter www.joerger.de · Further products see www.joerger.de



Unterputz-Thermostat $\frac{3}{4}$ " mit Ventil-Modulen in Gold
Concealed wall thermostat $\frac{3}{4}$ " with valve modules in gold



1 637.13.202.xxx



2 637.40.460.xxx +
649.40.360.000



3 637.40.380.xxx + 649.40.360.000



4 637.40.560.xxx +
649.40.555.000



5 649.13.615.xxx + 649.13.625.xxx



8 637.20.237.xxx +
649.20.237.xxx

7 637.13.237.xxx



6 637.60.432.xxx +
649.20.610.000



9 649.13.930.xxx + 649.13.770.xxx



10 637.60.435.xxx +
649.20.610.000



11 637.13.302.xxx

1 | Schlauchbrausegarnitur · Shower combination **2** | Unterputz-Thermostat ½" · Concealed wall thermostat ½" **3** | Unterputz-Thermostat ½" mit Mengenregulierung · Concealed wall thermostat ½" with flow control **4** | Unterputz-Thermostat ¾" · Concealed wall thermostat ¾" **5** | Stachelkopfbrause ½" + Wandarm · Body spray shower head ½" + Wall bracket **6** | Unterputz-Ventil-Modul ¾" · Concealed wall valve modul ¾" **7** | Hygienebrausegarnitur · Ablution spray combination **8** | 1-Hand Batterie ½" für Hygiene-Brause · Concealed single lever ½" for ablution spray **9** | Regenbrause ½", ø 300 mm + Deckenanbindung · Rain shower head ½", ø 300 mm + ceiling bracket **10** | Unterputz-Ventil-Modul ¾" · Concealed wall valve modul ¾" **11** | Duschgarnitur mit Duschstange 780 mm · Shower bar set, complete, wall bar 780 mm

Weitere Produkte unter www.joerger.de · Further products see www.joerger.de



Wannenfüll- und Brausebatterie für Standrohrmontage in Edelmessing
Tub/shower mixer for supply pipes in sunshine





Wand-Waschtisch 3-Loch Batterie in Edelmessing
Washbasin 3-hole mixer in sunshine



Fein komponiertes Ensemble in Edelmessing –
von Meisterhand entworfen und gefertigt

FINELY COMPOSED BATHROOM DESIGN – MANUALLY AND INDIVIDUALLY MADE BY EXPERTS





Unterputz Thermostat ½" mit Umstellung und Schlauchbrausegarnitur in Edelmessing
Concealed thermostat ½" with diverter and shower combination in sunshine



Klassisch-elegantes Design und pures Duschvergnügen mit CRONOS in Edelmessing. Das komfortable Duschsystem mit Thermostat-Brausebatterie glänzt nicht nur durch sein Aussehen, sondern erfüllt auch alle Ansprüche, die Kunden von heute an ein modernes Badezimmer stellen.

Classy elegant design, pure showering pleasure: the comfortable CRONOS thermostatic shower system in sunshine not only looks fantastic but also meets all the demands that today's customers place on a modern bathroom by saving water and energy.



Duschsystem mit Aufputz Thermostat und Regenbrause 200 mm, Schwammkorb in Edelmessing · Shower system with exposed thermostat and rain shower head 200 mm, sponge basket in sunshine



Wand-Waschtisch 3-Loch Batterie und Accessoires in Edelmessing · Wall washbasin 3-hole mixer in sunshine



1 637.00.014.xxx



2 637.00.022.xxx



3 637.00.006.xxx



4 637.00.036.xxx



5 637.00.002.xxx



6 637.00.007.xxx



7 637.00.040.xxx



9 637.00.047.xxx



8 631.00.017.xxx



10 631.00.016.xxx



11 637.00.001.xxx



12 637.00.061.xxx

Oberflächen und Veredelungen

SURFACES AND FINISHES



(.000) Chrom
chrome



(.095) Nerz
mink



(.035) Silbernickel
polished nickel



(.040) Edelmessing
sunshine



(.011) Bronze
bronze



(.096) Nerz matt
mink matt



(.036) Nickel matt
satin nickel



(.041) Edelmessing matt
sunshine matt



(.065) Platin
platinum



(.022) Roségold
rose gold



(.020) Gold
gold



(.092) Schwarz matt
black matt



(.066) Platin matt
platinum matt



(.023) Roségold matt
rose gold matt



(.021) Gold matt
gold matt



(.052) Weiß matt
white matt



CRONOS CRYSTAL

Von ewiger Schönheit und zeitloser Wertigkeit

OF ETERNAL BEAUTY AND TIMELESS VALUE

CRONOS CRYSTAL kombiniert luxuriöse Akzente mit klassischer Eleganz zu zeitloser Wertigkeit im Bad. Kugelförmige, facettierte Kristallgriffe von hochwertiger Qualität schmücken diese Premiumkollektion. Modernes Design verbindet sich mit klassischen Elementen. An antike Säulen erinnernd, prägen feine Rillen Auslauf und Körper der schönen Badarmatur.

CRONOS CRYSTAL combines luxurious accents and classical elegance into timeless significance in the bathroom. Round, faceted crystal handles characterise this premium collection. Modern design exists in harmony with the classic elements. Fine grooves adorn the spout and body of this beautiful bathroom fitting, reminiscent of ancient pillars.





Design und Handwerkskunst stecken im Detail

DESIGN AND CRAFTSMANSHIP ARE IN THE DETAILS





Waschtisch 3-Loch Batterie und Accessoires in Roségold
Washbasin 3-hole mixer and accessories in rose gold



CRONOS CRYSTAL in Gold – Luxus pur im Bad

AUTHENTIC LUXURY IN THE BATHROOM – CRONOS CRYSTAL IN GOLD





1 637.30.300.xxx-11



2 637.12.100.xxx-11



3 637.10.100.xxx-11



4 637.30.360.xxx-11 + 649.30.380.000

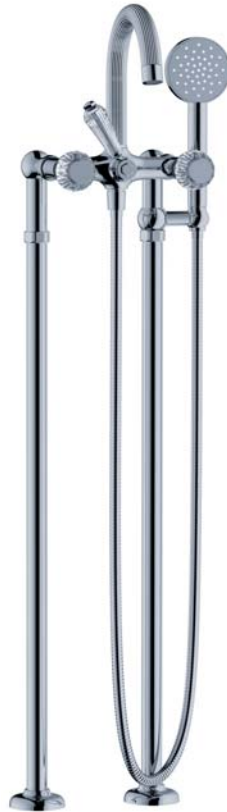

5 637.20.142.xxx-11 + 600.15.260.000



6 637.40.152.xxx-11



7 637.40.102.xxx-11



8 637.11.100.xxx



9 637.20.102.xxx-11

1 | Waschtisch 3-Loch Batterie ½", Ausladung 160 mm · Washbasin 3-hole mixer, spout projection 160 mm 2 | Eckventil ½" · Angle valve ½" 3 | Bidet 1-Loch Batterie · Bidet 1-hole mixer 4 | Wand-Waschtisch 3-Loch Batterie, Ausladung 190 - 215 mm · Wall washbasin 3-hole mixer, spout projection 190 - 215 mm 5 | Wannenfüll- und Brausebatterie für Standrohrmontage · Tub/shower mixer for supply pipes 6 | 4-Loch Wannenrandkombination ½" · Tub/shower combination ½" 7 | 4-Loch Wannenfüll- und Brausebatterie für Standmontage · Tub/shower mixer set, deck mount 8 | Wand-Wannenlauf ½" · Tub wall spout ½" 9 | Wannenfüll- und Brausebatterie ½" für Aufputzmontage, mit Garnitur · Exposed tub/shower mixer ½", incl. shower set

Weitere Produkte unter www.joerger.de · Further products see www.joerger.de



4-Loch Wannenfüll- und Brausebatterie in Gold
Tub/shower mixer set in gold



1 637.40.555.xxx-11 + 649.40.555.000



2 637.40.460.xxx + 649.40.360.000



4 637.60.432.xxx-11 + 649.20.610.000



3 637.40.380.xxx-11 + 649.40.360.000



5 637.13.202.xxx

6 637.13.312.xxx



7 637.13.237.xxx



10 637.20.462.xxx-11



8 637.20.200.xxx-11



9 129.20.237.xxx-11 + 649.20.237.xxx



11 637.20.250.xxx-11

1 | Unterputz-Thermostat 3/4" · Concealed wall thermostat 3/4" **2** | Unterputz-Thermostat 1/2" · Concealed wall thermostat 1/2" **3** | Unterputz-Thermostat 1/2" mit Mengenregulierung · Concealed wall thermostat 1/2" with flow control **4** | Unterputz-Ventil-Modul 3/4" · Concealed wall valve modul 3/4" **5** | Schlauchbrausegarnitur · Shower combination **6** | Duschgarnitur mit Duschstange 780 mm · Shower bar set, complete, wall bar 780 mm **7** | Hygienebrausegarnitur · Ablution spray combination **8** | Brausebatterie für Aufputzmontage 1/2" · Exposed shower mixer 1/2" **9** | 1-Hand Batterie 1/2" für Hygiene-Brause · Concealed single lever 1/2" for ablution spray **10** | Duschsystem mit Aufputz Brausethermostat 1/2", Regenbrause ø 240 mm · Shower system with exposed thermostat 1/2", rainshower ø 240 mm **11** | Brausethermostat 1/2" für Aufputzmontage · Exposed shower thermostat 1/2"

Weitere Produkte unter www.joerger.de · Further products see www.joerger.de



Unterputz-Thermostat $\frac{3}{4}$ " mit Ventil-Modulen in Gold
Concealed wall thermostat $\frac{3}{4}$ " with valve modules in gold



Funkelnder Luxus in Gold

SPARKLING LUXURY IN GOLD

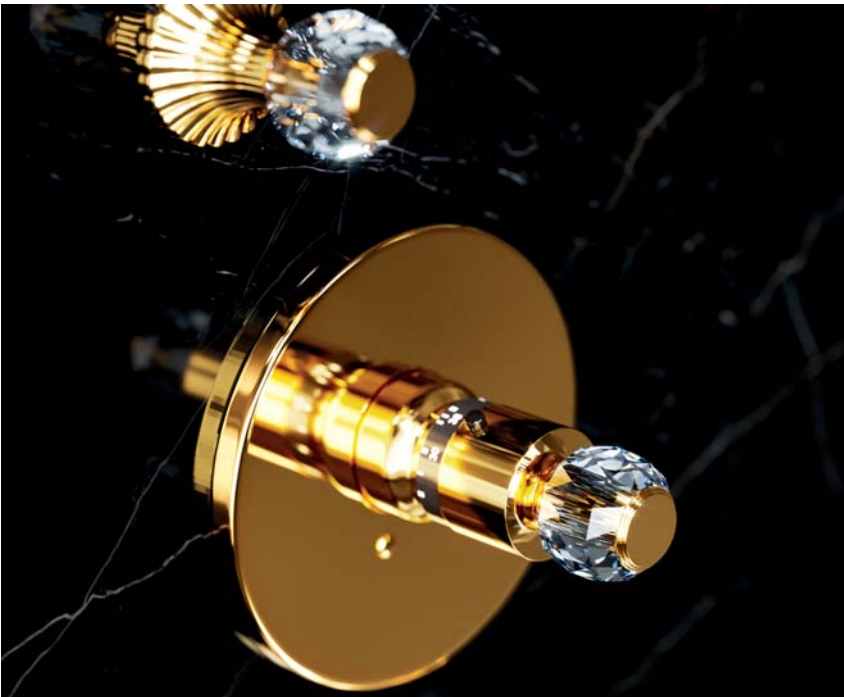



Duschkombination, Hygienebrausegarnitur und Accessoires in Gold · Shower combination, hygiene shower fitting and accessories in gold



Waschtisch 3-Loch Batterien, Seifenhalter in Edelmessing
Washbasin 3-hole mixers, soap dish holder in sunshine

jörger
DESIGN 

Die konsequent in allen Komponenten von CRONOS CRYSTAL umgesetzte Formensprache prägt das Erscheinungsbild des Bades. Die elegant geriffelte Rosette spielt dabei als charakteristisches und schmückendes Designelement für die vielfältigen Accessoires der Kollektion die zentrale Rolle.

The distinctive form, which is found in all components, shapes the look of the bathroom. The finely fluted rosette acts as a characteristic design element and plays a central role by adorning the collection's diverse accessories.





Lotionspender und Glashalter in Edelmessing · *Soap dispenser and tumbler holder in sunshine*



1 631.00.046.xxx



2 637.00.007.xxx



3 637.00.014.xxx



4 637.00.036.xxx



5 637.00.031.xxx



6 637.00.022.xxx



7 637.00.030.xxx



9 637.00.104.xxx



8 631.00.017.xxx



10 631.00.016.xxx



11 637.00.015.xxx



12 637.00.000.xxx

1 | Glashalter, freistehend · *Tumbler holder, free standing* 2 | Seifenhalter · *Soap dish holder* 3 | Papierhalter · *Toilet paper roll holder* 4 | Glashalter · *Tumbler holder*
 5 | Wannengriff · *Tub handle* 6 | Handtuchhaken · *Robe hanger* 7 | Duschtürgriff, 550 mm · *Handle for shower enclosure, 550 mm* 8 | Seifenhalter, freistehend · *Soap dish holder, free standing* 9 | Gästehandtuchkorb, 260 x 150 x 190 mm · *Guest towel basket, 260 x 150 x 190 mm* 10 | Lotionspender, freistehend · *Soap dispenser, free standing*
 11 | Reserve-Papierhalter · *Spare toilet paper roll holder* 12 | Klosettbürstengarnitur · *Toilet brush holder set*

Weitere Produkte unter www.joerger.de · *Further products see www.joerger.de*

CRONOS CRYSTAL in Gold matt – eine Klasse für sich

CRONOS CRYSTAL IN GOLD MATT IS IN A CLASS OF ITS OWN





CRONOS CRYSTAL bietet ein reiches Sortiment an Armaturen und Accessoires für Waschtisch, Bidet und auch für Badewanne und Dusche. Mit den Kristallkugeln setzt die Kollektion glitzernde Akzente im Bad. Jeder mit 96 Facetten geschliffene Kristall ist Ausdruck meisterhafter Kunstfertigkeit.

CRONOS CRYSTAL offers a wide range of fittings and accessories for washbasins, bidets and also for bathtubs and showers. With the crystal balls, the collection sets glittering accents in the bathroom. Each crystal cut with 96 facets is an expression of masterly craftsmanship.



Duschsystem mit Aufputz Thermostat und Regenbrause 200 mm, Schwammkorb in Gold matt · Shower system with exposed thermostat and rain shower head 200 mm, sponge basket in gold matt



Armaturen und Accessoires in Gold matt · *Fittings and accessories in gold matt*



Accessoires und Bidet 1-Loch Batterie in Gold matt · Accessories and bidet 1-hole mixer in gold matt

Besonders erlesen und luxuriös wirkt
CRONOS CRYSTAL in Gold matt

THE GOLD MATT FINISH MAKES CRONOS CRYSTAL LOOK EXQUISITELY LUXURIOUS





Duschkombination mit Unterputz-Thermostat ½" in Silbernickel
Shower combination set with concealed thermostat ½" in polished nickel



Oberflächen und Veredelungen

SURFACES AND FINISHES



(.000) Chrom
chrome



(.095) Nerz
mink



(.035) Silbernichel
polished nickel



(.040) Edelmessing
sunshine



(.011) Bronze
bronze



(.096) Nerz matt
mink matt



(.036) Nickel matt
satin nickel



(.041) Edelmessing matt
sunshine matt



(.065) Platin
platinum



(.022) Roségold
rose gold



(.020) Gold
gold



(.092) Schwarz matt
black matt



(.066) Platin matt
platinum matt



(.023) Roségold matt
rose gold matt



(.021) Gold matt
gold matt



(.052) Weiß matt
white matt



(.025) Alt-Gold
antique gold



DELPHI

Nostalgischer Designklassiker

NOSTALGIC DESIGN CLASSIC FOR THE BATHROOM



Die klassische Kollektion DELPHI verbindet Inspirationen eleganter Kirchenglocken mit der zeitlosen Schönheit der Belle Époque zu einem nostalgischen Retrodesign.

The classical DELPHI bathroom collection combines inspirations of elegant church bells with the timeless beauty of the Belle Époque into a nostalgic retro design.



Jörger Design mit Liebe zum Detail: die zeitlos schöne DELPHI-Waschtischarmatur in Edelmessing matt. Ebenso schmuckvoll veredelt die Accessoires und das Zubehör zum Waschbecken.

Jörger Design with love for detail is reflected in the timelessly beautiful DELPHI fitting in sunshine matt and the accessories that are just as decoratively finished.







Individuelle Badgestaltung als ästhetisches Gesamtkonzept mit DELPHI in Edelmessing matt. Die klassische Kollektion zeichnet sich durch ein breit gefächertes Angebot an Armaturen und Accessoires aus – speziell auch für Dusche und Badewanne.

Individual bathroom design as an aesthetic all-round concept with DELPHI in sunshine matt. The classical collection is characterised by a wide range of fittings and accessories – especially also for shower and bathtub.



Duschsystem mit Aufputz Brausebatterie, Regenbrause \varnothing 240 mm und Schwammkörben in Edelmessing matt · Shower system with exposed shower mixer, rainshower \varnothing 240 mm and sponge baskets in sunshine matt



JÖRGER
DESIGN 

Wannenfüll- und Brausebatterie für Standrohrmontage in Edelmessing matt
Tub/shower mixer for supply pipes in sunshine matt

Jede Armatur (außer Hebelmischer) ist mit folgenden Griffvarianten kombinierbar (auf Anfrage sind auch schwarze und klare Kristallgriffe aus der Serie DELPHI DECO erhältlich).

Each tap (beside the single lever mixer) is available with the following handle styles (black and clear crystal handles from the collection DELPHI DECO are also available on request).



Kreuzgriff
Cross handle



Hebelgriff weiß
White lever handle



Hebelgriff Metall
Metal lever handle



Hebelgriff Craquelé
Craquelé lever handle



1 109.30.300.xxx



2 109.10.100.xxx



3 109.30.360.xxx + 649.30.380.000



5 109.10.300.xxx



4 109.12.100.xxx



6 649.15.340.xxx



7 109.40.100.xxx

1 | Waschtisch 3-Loch Batterie ½", Ausladung 165 mm · Washbasin 3-hole mixer, spout projection 165 mm 2 | Bidet 1-Loch Batterie · Bidet 1-hole mixer 3 | Wand-Waschtisch 3-Loch Batterie, Ausladung 215 - 230 mm · Wall washbasin 3-hole mixer, spout projection 215 - 230 mm 4 | Eckventil ½" · Angle valve ½" 5 | Waschtisch 1-Loch Batterie ½", Ausladung 165 mm · Washbasin 1-hole mixer, spout projection 165 mm 6 | Waschtisch-Tassensiphon 1 ¼" · Washbasin cupped siphon trap 1 ¼" 7 | 4-Loch Wannenfüll- und Brausebatterie für Standmontage · Tub/shower mixer set, deck mount

Weitere Produkte unter www.joerger.de · Further products see www.joerger.de



Premiere für DELPHI im
trendy Finish Gold matt

PREMIERE FOR DELPHI IN GOLD MATT FINISH





1 109.30.100.xxx



2 109.10.400.xxx



3 109.20.100.xxx



4 109.13.237.xxx



6 109.20.390.xxx



5 109.20.237.xxx +
649.20.237.xxx



7 109.11.100.xxx



8 109.20.140.xxx + 109.15.260.xxx

1 | Bidet 3-Loch Batterie 1/2" · Bidet 3-hole mixer 1/2" 2 | Standventil 1/2" · Deck mount tap 1/2" 3 | Wannenfüll- und Brausebatterie 1/2" für Aufputzmontage, mit Garnitur · Exposed tub/shower mixer 1/2", incl. shower set 4 | Hygienebrausegarnitur · Ablution spray combination 5 | 1-Hand Batterie 1/2" für Hygiene-Brause · Concealed single lever 1/2" for ablution spray 6 | Aufputz-Wannenfüll- und Brausesystem 1/2", Regenbrause ø 200 mm · Exposed tub/shower system 1/2", rainshower ø 200 mm 7 | Wand-Wannenleinlauf 1/2" · Tub wall spout 1/2" 8 | Wannenfüll- und Brausebatterie für Standrohrmontage · Tub/shower mixer for supply pipes

Weitere Produkte unter www.joerger.de · Further products see www.joerger.de



1 109.30.365.xxx + 649.30.380.000



2 109.10.105.xxx



3 109.30.305.xxx



4 109.10.111.xxx



5 109.10.333.xxx



6 109.10.337.xxx



7 109.10.305.xxx



8 109.40.155.xxx



9 109.10.405.xxx



10 109.40.105.xxx

1 | Wand-Waschtisch 3-Loch Batterie, Ausladung 215 - 230 mm · Wall washbasin 3-hole mixer, spout projection 215 - 230 mm 2 | Bidet 1-Loch Batterie · Bidet 1-hole mixer
 3 | Waschtisch 3-Loch Batterie 1/2", Ausladung 165 mm · Washbasin 3-hole mixer, spout projection 165 mm 4 | Bidet 1-Hand Batterie · Single lever bidet mixer
 5 | Waschtisch 1-Hand Batterie, Ausladung 165 mm · Single lever washbasin mixer, spout projection 165 mm 6 | Waschtisch 1-Hand Batterie mit Körperverlängerung, Gesamthöhe 340 mm · Single lever washbasin mixer with body extension, total height 340 mm 7 | Waschtisch 1-Loch Batterie 1/2", Ausladung 165 mm · Washbasin 1-hole mixer, spout projection 165 mm 8 | 4-Loch Wannenrandkombination 1/2" · Tub/shower combination 1/2" 9 | Standventil 1/2" · Deck mount tap 1/2" 10 | 4-Loch Wannenfüll- und Brausebatterie für Standmontage · Tub/shower mixer set, deck mount

Weitere Produkte unter www.joerger.de · Further products see www.joerger.de



Jörger
DESIGN 

Waschtisch 1-Hand Batterie in Chrom · Single lever washbasin mixer in chrome



DELPHI in Silbernickel – exklusive und luxuriöse Oberflächenveredelung. Ebenso schmuckvoll veredelt werden auf Wunsch Fremdfabrikate wie hier das Wannen-Abflussrohr oder das Tischbein des Beistelltischs. Auf der Basis individueller Kundenanfragen ist bei Jörger Vieles möglich.

DELPHI in polished nickel – exclusive and luxurious finish. On special request third-party products such as the tub drainpipe or the leg of the side table can also be plated matching to the decorative finishing. Jörger can do a lot to match individual customer queries.







Bidet 1-Hand Batterie und Accessoires in Silbernickel
Single lever bidet mixer and accessories in polished nickel

Die vielfältigen Accessoires greifen das Design stilgerecht auf. Exklusive, handverarbeitete Oberflächen verleihen dem nostalgischen Badambiente vollendete Harmonie.

The diverse accessories pick up on the design in style. Exclusive, hand-worked surfaces donate a perfect harmony to the nostalgic bathroom ambience.





jörger
design 

Wannenfüll- und Brausebatterie für Standrohrmontage in Silbernickel
Tub/shower mixer for supply pipes in polished nickel



1 109.20.105.xxx



2 109.20.205.xxx



3 109.30.105.xxx



4 109.20.255.xxx

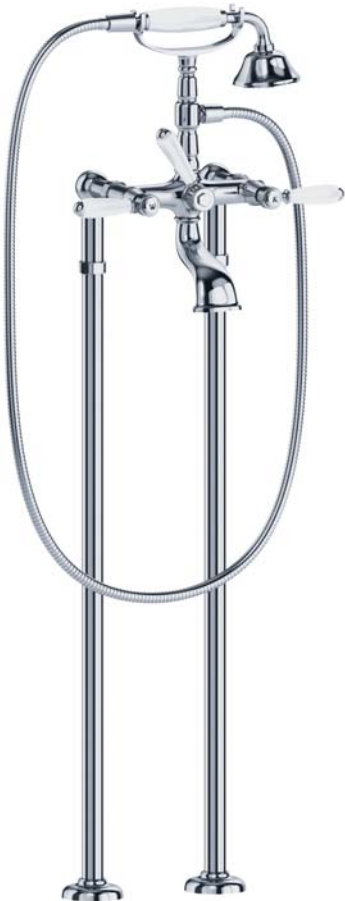

6 109.20.145.xxx + 109.15.260.xxx



7 109.20.395.xxx



5 109.20.500.xxx



8 109.20.600.xxx

1 | Wannenfüll- und Brausebatterie 1/2" für Aufputzmontage, mit Garnitur · Exposed tub/shower mixer 1/2", incl. shower set 2 | Brausebatterie für Aufputzmontage 1/2" · Exposed shower mixer 1/2" 3 | Bidet 3-Loch Batterie 1/2" · Bidet 3-hole mixer 1/2" 4 | Brausethermostat 1/2" für Aufputzmontage · Exposed shower thermostat 1/2" 5 | 1-Hand Aufputz-Wannenfüll- und Brausebatterie 1/2", mit Garnitur, Ausladung 175 mm · Single lever exposed tub/shower mixer 1/2", incl. shower set, spout projection 175 mm 6 | Wannenfüll- und Brausebatterie für Standrohrmontage · Tub/shower mixer for supply pipes 7 | Aufputz-Wannenfüll- und Brausesystem 1/2", Regenbrause ø 200 mm · Exposed tub/shower system 1/2", rainshower ø 200 mm 8 | 1-Hand Brausebatterie 1/2" für Aufputzmontage · Single lever exposed shower mixer 1/2"

Weitere Produkte unter www.joerger.de · Further products see www.joerger.de



1 109.40.380.xxx + 649.40.360.000



2 109.20.235.xxx + 649.40.360.000



3 109.20.125.xxx + 649.40.360.000



4 109.60.432.xxx + 649.20.610.000



6 109.20.410.xxx



5 109.40.560.xxx + 649.40.555.000



7 109.13.300.xxx



9 109.20.465.xxx



8 109.13.200.xxx

1 | Unterputz-Thermostat ½" mit Mengenregulierung · Concealed wall thermostat ½" with flow control 2 | 1-Hand Brausebatterie ½" für UP-Montage · Concealed single lever shower mixer ½" 3 | 1-Hand Wannenfüll- und Brausebatterie ½" für UP-Montage · Concealed single lever wall tub and shower mixer ½" 4 | Unterputz-Ventil-Modul · Concealed wall valve modul 5 | Unterputz-Thermostat ¾" · Concealed wall thermostat ¾" 6 | Duschsystem mit Aufputz Brausebatterie ½", Regenbrause ø 200 mm · Shower system with exposed shower mixer ½", rainshower ø 200 mm 7 | Duschgarnitur mit Duschstange 900 mm · Shower bar set, complete, wall bar 900 mm 8 | Schlauchbrausegarnitur · Shower combination 9 | Duschsystem mit Aufputz Brausethermostat ½", Regenbrause ø 200 mm · Shower system with exposed thermostat ½", rainshower ø 200 mm

Weitere Produkte unter www.joerger.de · Further products see www.joerger.de



Duschsystem und Accessoires in Silbernickel · Shower system and accessories in polished nickel



1 109.00.009.xxx



2 109.00.022.xxx



3 109.00.016.xxx



5 109.00.105.xxx



6 109.00.002.xxx

4 109.00.047.xxx



8 109.00.006.xxx



7 109.00.040.xxx



11 109.00.061.xxx

9 109.00.041.xxx



10 109.00.106.xxx

1 | Ablage, 600 mm · Shelf holder with glass, 600 mm 2 | Handtuchhaken · Robe hanger 3 | Lotionspender, freistehend · Soap dispenser, free standing 4 | Handtuchring
Towel ring 5 | Schwammkorb, rechteckig, 260 x 130 mm · Sponge basket, rectangular, 260 x 130 mm 6 | Handtuchhalter · Single towel bar 7 | Badetuchhalter · Bath
towel bar 8 | Lotionspender · Soap dispenser 9 | Badetuchhalter, doppelt · Bath towel bar, double 10 | Eckschwammkorb, 190 x 190 mm · Corner sponge basket,
190 x 190 mm 11 | Wandleuchte · Wall lamp

Weitere Produkte unter www.joerger.de · Further products see www.joerger.de



Armaturen und Accessoires in Silberrnickel - Taps and accessories in polished nickel



1 109.00.104.xxx



2 109.00.017.xxx



3 109.00.046.xxx



4 109.00.036.xxx



5 109.00.031.xxx



7 109.00.030.xxx



6 109.00.007.xxx



8 109.00.014.xxx



9 109.00.000.xxx



10 109.00.015.xxx



11 109.00.001.xxx

1 | Gästehandtuchkorb, 260 x 150 x 190 mm · Guest towel basket, 260 x 150 x 190 mm 2 | Seifenhalter, freistehend · Soap dish holder, free standing 3 | Glashalter, freistehend · Tumbler holder, free standing 4 | Glashalter · Tumbler holder 5 | Wannengriff · Tub handle 6 | Seifenhalter · Soap dish holder 7 | Duschtürgriff, 550 mm Handle for shower enclosure, 550 mm 8 | Papierhalter · Toilet paper roll holder 9 | Klossettbürstengarnitur · Toilet brush holder set, free standing 10 | Reserve-Papierhalter · Spare toilet paper roll holder 11 | Klossettbürstengarnitur, freistehend · Toilet brush holder set, free standing

Weitere Produkte unter www.joerger.de · Further products see www.joerger.de



Seifenhalter, Glashalter in Silbernickel - Soap dish holder, tumbler holder in polished nickel



Waschtisch 3-Loch Batterie mit Hebelgriff Craquelé und Accessoires in Edelmessing,
Hebelgriff Craquelé in Nerz
*Washbasin 3-hole mixer with craquelé lever handle and accessories in sunshine,
craquelé lever handle in mink*

Luxuriöse Badgestaltung im Vintage-Look

LUXURIOUS BATHROOM SETTING IN NOSTALGIC VINTAGE LOOK WITH DELPHI



JÖRGER
DESIGN



Oberflächen und Veredelungen

SURFACES AND FINISHES



(.000) Chrom
chrome



(.095) Nerz
mink



(.035) Silbernickel
polished nickel



(.040) Edelmessing
sunshine



(.011) Bronze
bronze



(.096) Nerz matt
mink matt



(.036) Nickel matt
satın nickel



(.041) Edelmessing matt
sunshine matt



(.065) Platin
platinum



(.022) Roségold
rose gold



(.020) Gold
gold



(.092) Schwarz matt
black matt



(.066) Platin matt
platinum matt



(.023) Roségold matt
rose gold matt



(.021) Gold matt
gold matt



(.052) Weiß matt
white matt

Roségold und weißes Porzellan mit Craquelé – Romantik pur

ROSE GOLD AND WHITE CRAQUELÉ PORCELAIN – PURE ROMANCE



Waschtisch 1-Hand Batterie in Roségold mit Hebelgriff Craquelé
Single lever washbasin mixer in rose gold with craquelé lever handle



FLORALE CRYSTAL

Kristalle in strahlender Blüte

COLOURED CRYSTALS IN GLITTERING BLOOM

Magische Wirkung entsteht, wenn funkelnde Kristalle auf Licht und Wasser treffen. Das luxuriöse Design der Kollektion FLORALE CRYSTAL verbindet Kristalle und florale Formen zu einem zeitlosen Gesamtkunstwerk.

Hochwertig geschliffen, schmücken facettierte Kristalle in verschiedenen Farben die Griffe der harmonisch geformten Armaturen. Die vielfältigen Accessoires greifen das Design durchgängig auf.

A magic effect is created when glittering crystals meet light and water. The luxurious design of the FLORALE CRYSTAL collection combines timeless crystals and floral forms to one single work of art.

Sophistically polished, faceted crystals in various colours adorn the handles of the harmoniously shaped fittings. A wide range of accessories pick up on the design throughout the whole collection.





Schmuckdesign von ganz besonderem Stil

JEWELLERY DESIGN OF A VERY SPECIAL STYLE





Besonders schön und wirkungsvoll ist die Kombination der Oberfläche Silbernickel mit den amethystfarbenen Kristallen. Wie Schmuckstücke ziehen die dekorativen Kristalle alle Blicke auf sich. Sie sind bestimmendes Element des insgesamt harmonisch abgestimmten Designs von Armaturen und Accessoires.

The combination of polished nickel surface with the amethyst colored crystal handles is particularly beautiful and stylish. The decorative handles attracts admiring glances like jewellery pieces. They are the defining element of the overall harmoniously coordinated design of fittings and accessories.







Armaturen in Edelmessing - *Fittings in sunshine*



Luxuriöses Dreamteam der warmen Goldtöne

LUXURIOUS DREAM TEAM OF WARM GOLD TONES





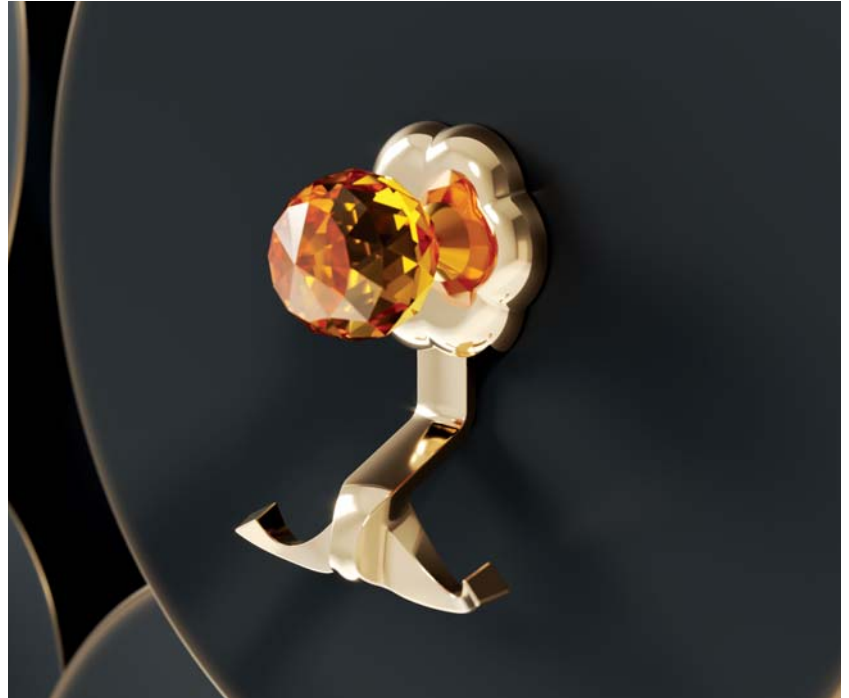

Herausragende Gestaltung und hochwertige, handwerkliche Produktion mit Liebe zum Detail: FLORALE CRYSTAL in Edelmessing.

Das Design der luxuriösen Armaturen und Accessories mit bernsteinfarbenen Kristallen ist vollkommen harmonisch abgestimmt.

Outstanding shapes and high-quality, handcrafted production with love for details: FLORALE CRYSTAL in sunshine.

The design of the luxurious fittings and accessories with amber-colored crystals is perfectly coordinated.









Wannenfüll- und Brausebatterie für Standrohrmontage in Platin
Tub/shower mixer for supply pipes in platinum

Jörger
DESIGN 



Wannenfüll- und Brausebatterien für
Standrohrmontage in Gold beziehungsweise Silbernickel
Tub/shower mixers for supply pipes in gold respectively polished nickel



1 600.30.300.xxx-AA



2 600.10.300.xxx-AA



3 600.30.360.xxx-AA + 649.30.380.000



4 600.40.100.xxx-AA



5 600.10.100.xxx-AA

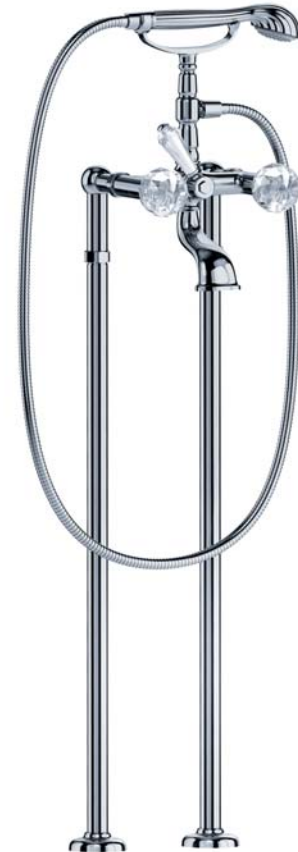

8 600.20.149.xxx-AA + 109.15.260.xxx



6 600.20.109.xxx-AA



7 600.11.100.xxx

1 | Waschtisch 3-Loch Batterie ½", Ausladung 130 mm · Washbasin 3-hole mixer ½", spout projection 130 mm 2 | Waschtisch 1-Loch Batterie ½", Ausladung 130 mm
 Washbasin 1-hole mixer ½", spout projection 130 mm 3 | Wand-Waschtisch 3-Loch Batterie, Ausladung 160 - 175 mm · Wall washbasin 3-hole mixer, spout projection
 160 - 175 mm 4 | 4-Loch Wannenfäll- und Brausebatterie für Standmontage · Tub/shower mixer set, deck mount 5 | Bidet 1-Loch Batterie · Bidet 1-hole mixer 6 | Wannenfäll-
 und Brausebatterie ½" für Aufputzmontage, mit Garnitur · Exposed tub/shower mixer ½", incl. shower set 7 | Wand-Wanneneinlauf ¾" · Tub wall spout ¾" 8 | Wannenfäll- und
 Brausebatterie für Standrohrmontage · Tub/shower mixer for supply pipes

Weitere Produkte unter www.joerger.de | Further products see www.joerger.de



Wannenfüll- und Brausebatterie für Standrohrmontage in Silbernickel
Tub/shower mixer for supply pipes in polished nickel



1 600.40.380.xxx-AA + 649.40.360.000



2 600.40.560.xxx-AA + 649.40.555.000



3 600.40.520.xxx-AA + 649.40.520.000



4 600.60.432.xxx-AA + 649.20.610.000



5 600.20.410.xxx-AA



6 600.20.460.xxx-AA



7 605.20.237.xxx-AA + 649.20.237.xxx



9 600.13.237.xxx



8 600.20.200.xxx-AA



10 600.13.200.xxx



11 600.13.310.xxx-AA

1 | Unterputz-Thermostat ½" mit Mengenregulierung · *Concealed wall thermostat ½" with flow control* 2 | Unterputz-Thermostat ¾" mit hohem Durchfluß · *Concealed wall thermostat ¾" with high flow* 3 | Unterputz-Thermostat ¾" · *Concealed wall thermostat ¾"* 4 | Unterputz-Ventil-Modul ¾" · *Concealed wall valve modul ¾"* 5 | Duschsystem mit Aufputz Brausebatterie ½", Regenbrause ø 240 mm · *Shower system with exposed shower mixer ½", rainshower ø 240 mm* 6 | Duschsystem mit Aufputz Brausethermostat ½", Regenbrause ø 240 mm · *Shower system with exposed thermostat ½", rainshower ø 240 mm* 7 | 1-Hand Batterie ½" für Hygiene-Brause · *Concealed single lever mixer ½" for ablution spray* 8 | Brausebatterie ½" für Aufputzmontage · *Exposed shower mixer ½"* 9 | Hygienebrausegarnitur · *Ablution spray combination* 10 | Schlauchbrausegarnitur · *Shower bar set, complete, wall bar 780 mm*

Weitere Produkte unter www.joerger.de | *Further products see www.joerger.de*



Unterputz-Thermostat $\frac{3}{4}$ " mit Ventil-Modulen und Schlauchbrausegarnitur in Silbernickel
Concealed wall thermostat $\frac{3}{4}$ " with valve modules and shower combination in polished nickel





1 600.00.022.xxx-AA



2 600.00.007.xxx-AA



3 600.00.036.xxx-AA



4 600.00.002.xxx-AA



5 600.00.047.xxx-AA



6 600.00.040.xxx-AA



7 600.00.014.xxx-AA



8 600.00.031.xxx-AA



9 600.00.015.xxx-AA



10 600.00.000.xxx-AA

1 | Handtuchhaken · Robe hanger 2 | Seifenhalter · Soap dish holder 3 | Glashalter · Tumbler holder 4 | Handtuchhalter · Single towel bar 5 | Handtuchring · Towel ring
 6 | Badetuchhalter · Bath towel bar 7 | Papierhalter · Toilet paper roll holder 8 | Wannengriff · Tub handle 9 | Reserve-Papierhalter · Spare toilet paper roll holder
 10 | Klosettbürstengarnitur · Toilet brush holder set

Weitere Produkte unter www.joerger.de | Further products see www.joerger.de

Oberflächen und Veredelungen

SURFACES AND FINISHES



(.000) Chrom
chrome



(.095) Nerz
mink



(.035) Silbernickel
polished nickel



(.040) Edelmessing
sunshine



(.011) Bronze
bronze



(.096) Nerz matt
mink matt



(.036) Nickel matt
satin nickel



(.041) Edelmessing matt
sunshine matt



(.065) Platin
platinum



(.022) Roségold
rose gold



(.020) Gold
gold



(.092) Schwarz matt
black matt



(.066) Platin matt
platinum matt



(.023) Roségold matt
rose gold matt



(.021) Gold matt
gold matt



(.052) Weiß matt
white matt





Wand-Waschtisch 3-Loch Batterie in Roségold
Wall washbasin 3-hole mixer in rose gold



(-11) kristallklar
clear as crystal



(-12) schwarz
black



(-16) bernstein
amber



(-17) amethyst
amethyst

mehr auf | more at
www.joerger.de





ACUBO
Waschtisch 1-Hand Batterie in Nerz matt
Single lever washbasin mixer in mink matt



PLATEAU
Waschtisch 1-Hand Batterie in Schwarz matt/Chrom
Single lever washbasin mixer in black matt/chrome



DELPHI DECO
Waschtisch 3-Loch Batterie in Chrom
Washbasin 3-hole mixer in chrome



SERIE 1909
Waschtisch 3-Loch Batterie in Nerz matt
Washbasin 3-hole mixer in mink matt



APHRODITE
Waschtisch 3-Loch Batterie in Alt-Gold
Washbasin 3-hole mixer in antique gold



PALAZZO CRYSTAL
Waschtisch 3-Loch Batterie in Chrom
Washbasin 3-hole mixer in chrome



EMPIRE II
Waschtisch 3-Loch Batterie in Chrom
Washbasin 3-hole mixer in chrome



ALBANO
Waschtisch 3-Loch Batterie in Chrom
Washbasin 3-hole mixer in chrome



MUSCHEL
Waschtisch 3-Loch Batterie in Chrom/Gold
Washbasin 3-hole mixer in chrome/gold



MINARETT
4-Loch Wannenfüll- und Brausebatterie in Gold
4-hole tub/shower mixer set in gold

IMPRESSUM

Herausgeber: Joger Armaturen- und Accessoiresfabrik GmbH, Mannheim

Art Direction / Graphic Design: Oliver M. Joger

Fotografie: belyan.design.studio, u.a.

Text: Angelika Bohm

© Copyright: Joger Armaturen- und Accessoiresfabrik GmbH, Mannheim (Germany) / Stand: 7/2021

Nachdruck oder Vervielfaltung, gleichgultig nach welchem Verfahren, auch auszugsweise, ist nur mit unserer Genehmigung zulassig.

Abmessungen und Farben unterliegen den ublichen Toleranzen.

Modelle und technische Details entsprechen bei Druck dem letzten Stand. Technische Konstruktions- und Modellveranderungen im Sinne des Fortschritts behalten wir uns vor. Druckfehler vorbehalten.

Reproduction or duplication of any part of this catalogue, in any manner, is authorised only with our permission.

Dimensions and colours are subject to usual allowance.

Models and technical details shown are final. We reserve the right to technical improvements and/or changes. Subject to printing errors.



JÖRGER ARMATUREN- UND ACCESSOIRESFABRIK GMBH
Seckenheimer Landstraße 270-280 | 68163 Mannheim / Germany | Telefon: +49 621 41097-01 | E-Mail: info@joerger.de
WWW.JOERGER.DE